

ACTIFLEX TABLES

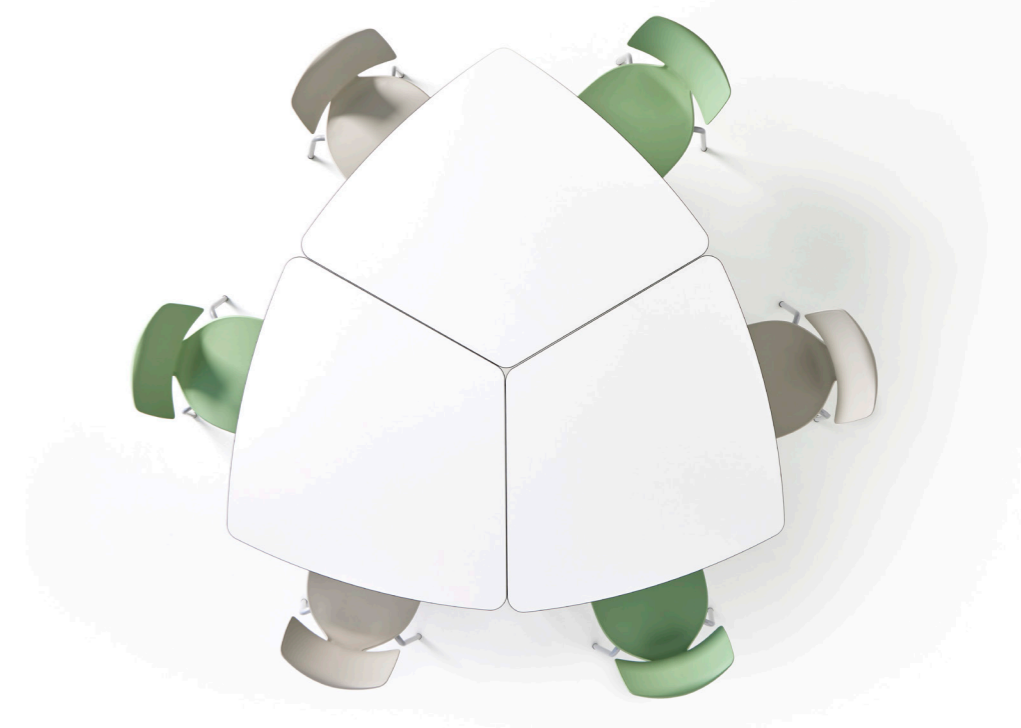

Tu imaginación es el límite

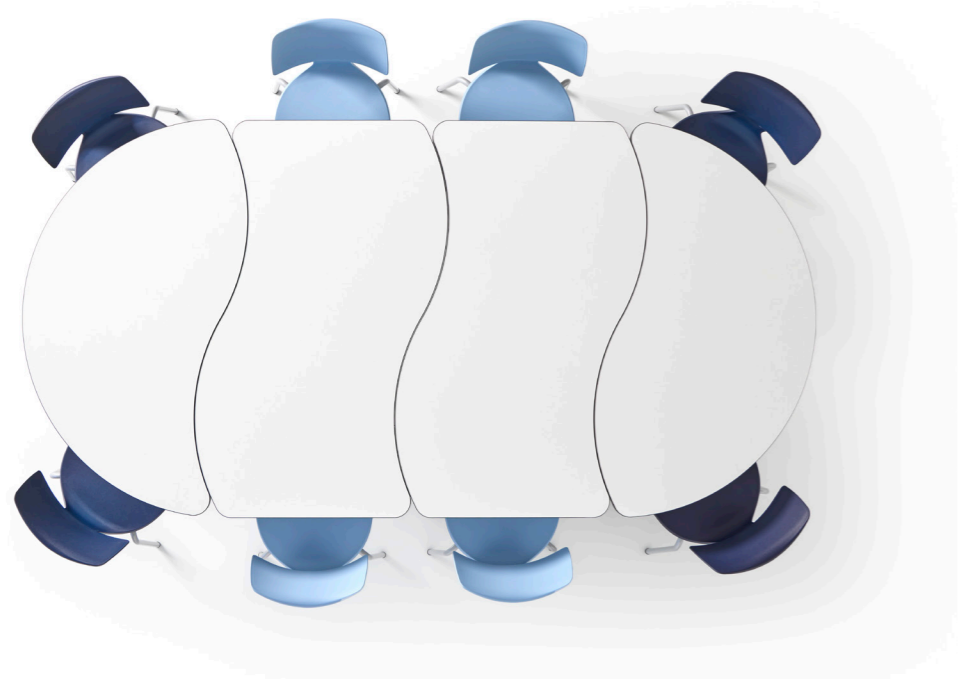

ES

Federico Giner se caracteriza por un diseño puro y elegante junto a una funcionalidad óptima para adaptarse a las necesidades de nuestros clientes.

Basándonos en estos valores, y anticipándonos a las exigencias de un mercado cada vez más cambiante, Federico Giner presenta su colección **Actiflex Tables**.

Un conjunto de mesas modulares con diferentes formas que personalizan cualquier espacio dotándolo del carácter que se merece. Mesas polivalentes, móviles o fijas, en madera o metálicas y con diferentes alturas o diámetros, cuyo denominador común no es otro, que la calidad de sus materias primas, y un proceso de fabricación en el que se mima hasta el más mínimo detalle.

EN

Federico Giner is characterized by a pure and elegant design together with optimal functionality to adapt to the needs of our clients.

*Based on these values, and anticipating the demands of an increasingly changing market, Federico Giner presents its collection **Actiflex Tables**.*

A set of modular tables with different shapes that personalize any space giving it the character it deserves. Multipurpose tables, mobile or fixed, in wood or metal and with different heights or diameters, whose common denominator is none other than the quality of its raw materials, and a manufacturing process in which even the smallest detail is pampered.

FR

Federico Giner se caractérise par un design pur et élégant ainsi qu'une fonctionnalité optimale pour répondre aux besoins de nos clients.

*Sur la base de ces valeurs, et en anticipant les exigences d'un marché de plus en plus changeant, Federico Giner présente sa collection **Actiflex Tables**.*

Un ensemble de tables modulaires aux formes différentes qui personnalisent tout espace en lui donnant le caractère qu'il mérite. Des tables polyvalentes, mobiles ou fixes, en bois ou en métal, de différentes hauteurs ou de différents diamètres, dont le dénominateur commun n'est autre que la qualité de ses matières premières et un processus de fabrication où chaque détail est soigné.

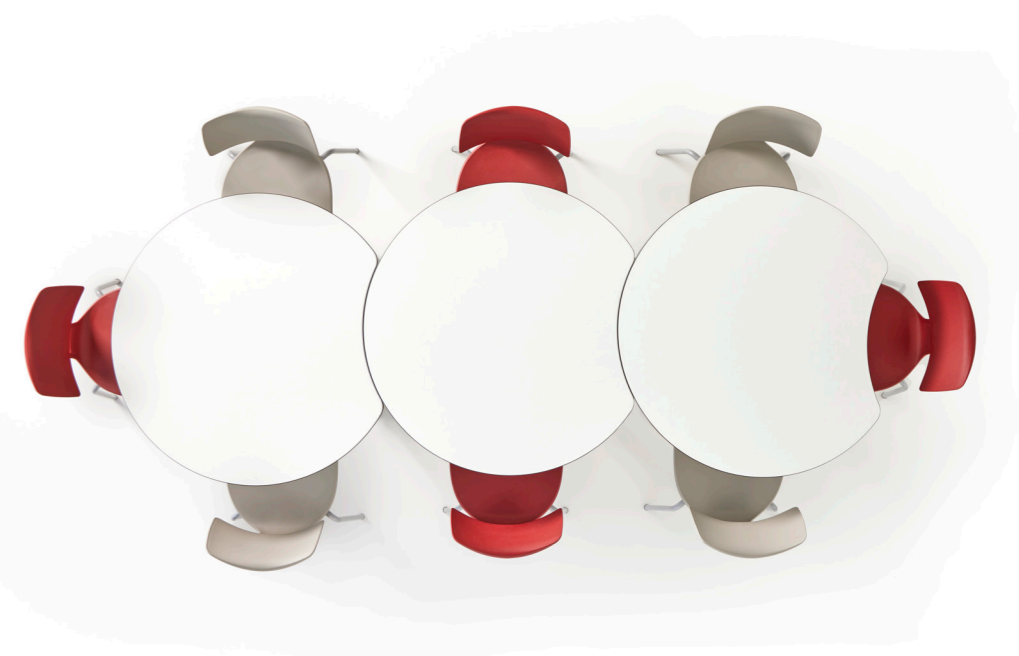



“ Una pieza que ha venido a **revolucionar** la construcción de las **mesas escolares** ”

ES

En **Federico Giner** seguimos innovando de la mano de la vanguardia tecnológica. A partir de un trabajo de más de un año en colaboración con el estudio de diseño Alegre Design, hemos desarrollado una pieza que ha venido a revolucionar la construcción de las mesas escolares.

Fabricada en inyección de aluminio, nuestra peana permite adaptarse a cualquier forma de tablero de manera rápida y sencilla. Además, este nuevo sistema permite utilizar diferentes acabados tanto en metal como en madera, ofreciendo múltiples opciones para adaptarse al espacio de la mejor manera.

EN

At **Federico Giner** we continue to innovate at the forefront of technology. From a work of more than a year in collaboration with the design studio Alegre Design, we have developed a piece that has come to revolutionize the construction of school tables.

Manufactured in aluminium injection, our base can be adapted to any shape of board quickly and easily. In addition, this new system allows the use of different finishes in both metal and wood, offering multiple options to adapt to the space in the best way.

FR

Chez **Federico Giner**, nous continuons d'innover à la pointe de la technologie. A partir d'un travail de plus d'un an en collaboration avec le studio de design Alegre Design, nous avons développé une pièce qui est venue révolutionner la construction des tables d'école.

Fabriqué en injection d'aluminium, notre socle s'adapte rapidement et facilement à toutes les formes de panneaux. En outre, ce nouveau système permet d'utiliser différentes finitions en métal et en bois, offrant ainsi de multiples options pour s'adapter au mieux à l'espace.

* Modelo patentado a nivel comunitario /
Patented model at community level.

Elige tu **Actiflex Table** ®



Mesa Link
MODELO 150



Mesa Kite
MODELO 151



Mesa Diamond
MODELO 152



Mesa Loop
MODELO 153



Mesa Moon
MODELO 154



Mesa Bend
MODELO 155



Mesa Half
MODELO 150



Mesa Mopac
MODELO 158



Mesa Yang
MODELO 159

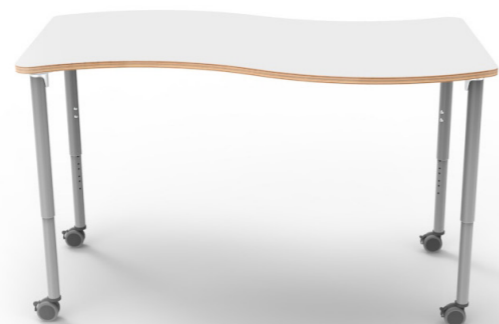

Mesa Wave
MODELO 160



Mesa 3-4-5
MODELO 345

LINK

MODELO 150

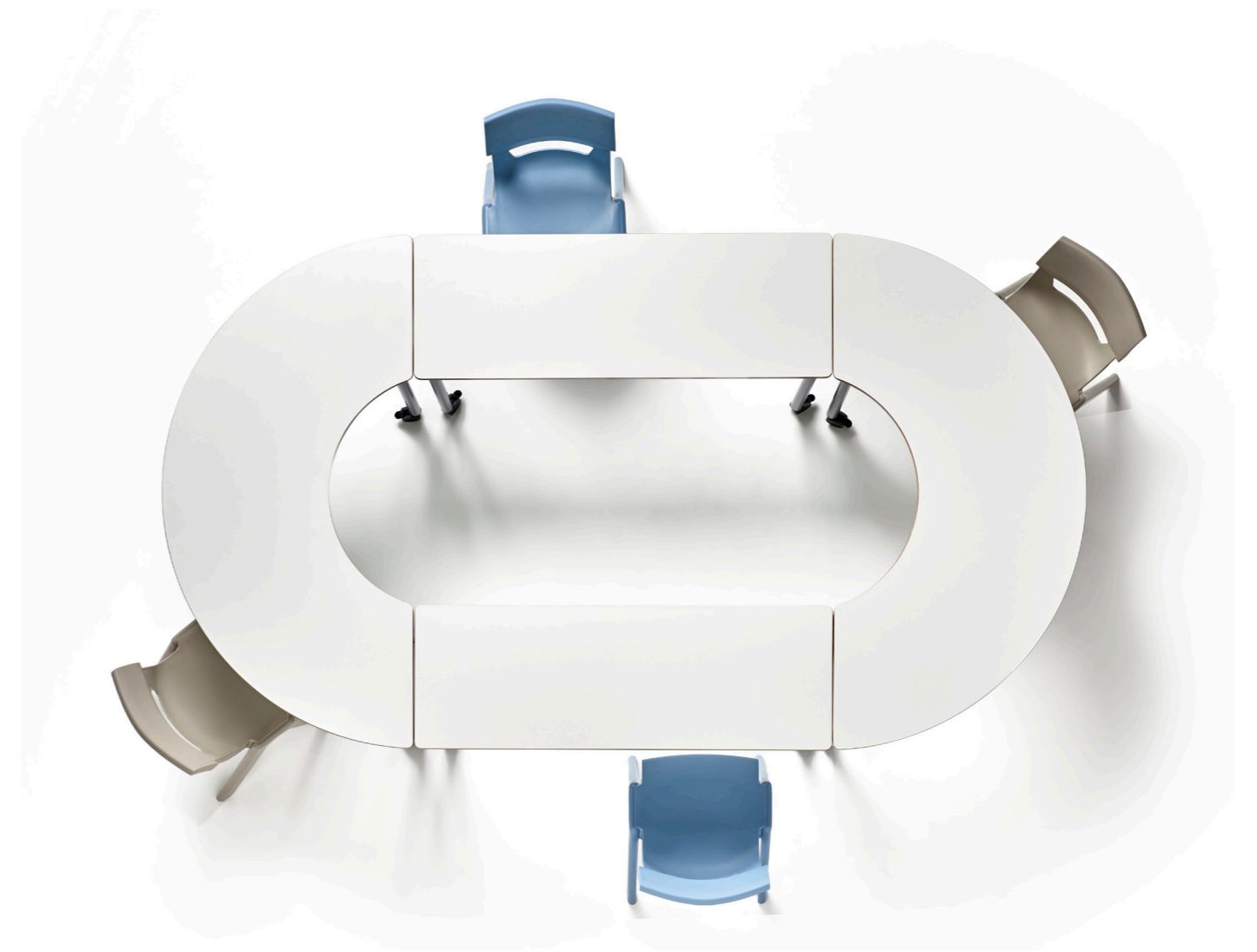

Acabados

Finishes / Finitions

MADERA / WOOD / BOIS



Blanco
White / Blanc

PATAS / LEGS / PIEDS



Aluminio
Aluminium / Aluminium



Haya
Beech / Hêtre

Detalles

Details / Détails



Medidas

Measures / Mesures

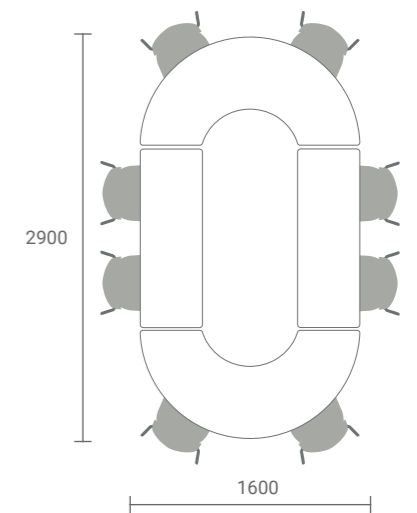
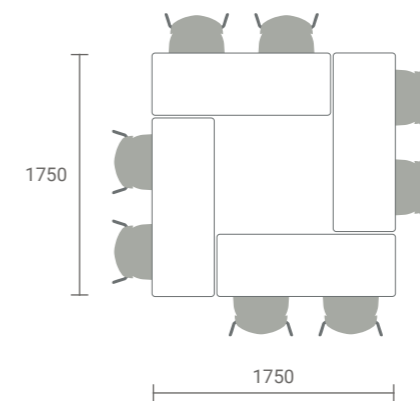
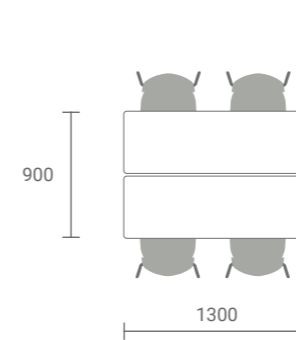
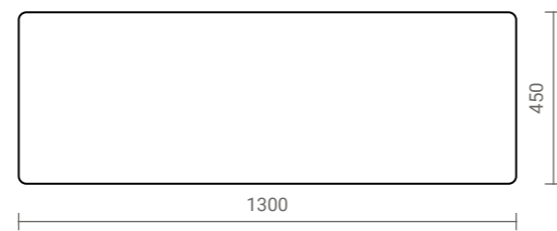



KITE

MODELO 151

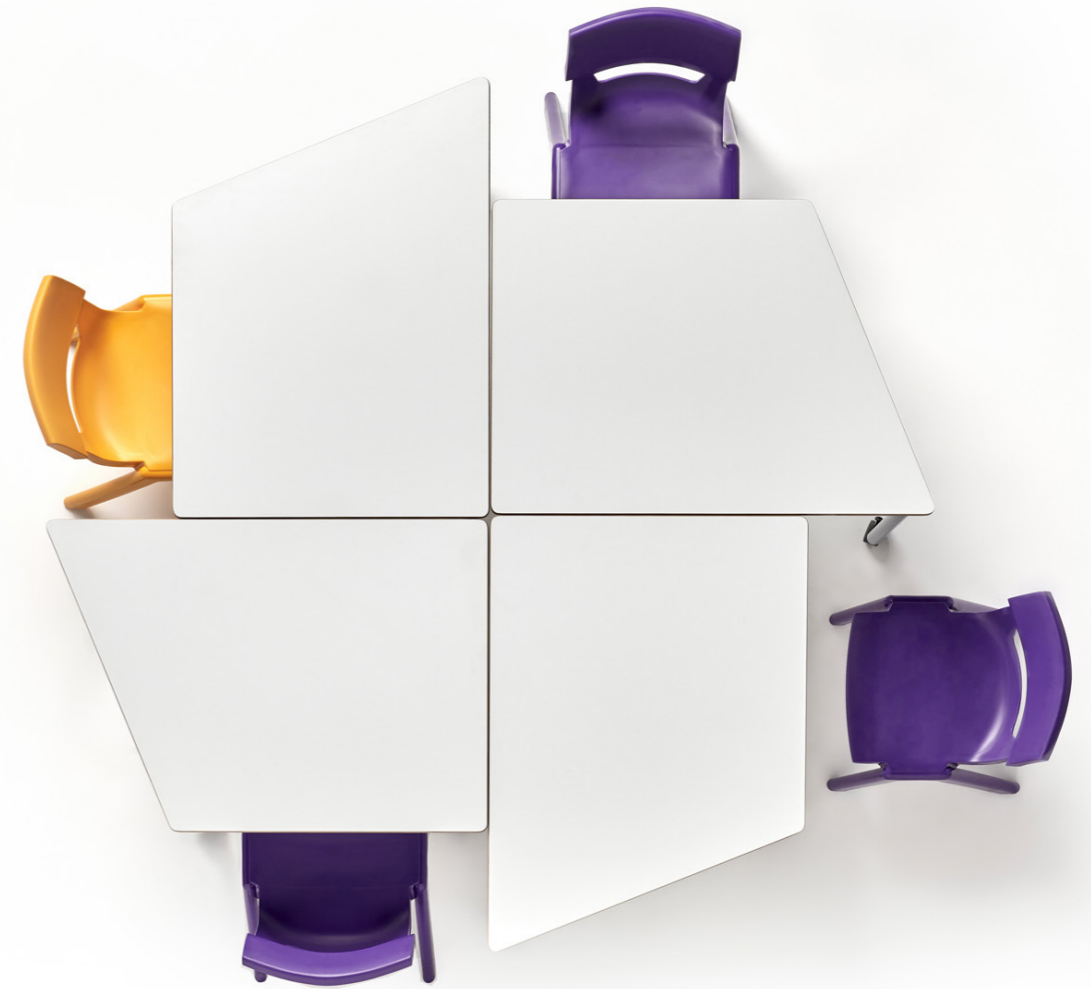

Acabados Finishes / Finitions

MADERA / WOOD / BOIS



Blanco
White / Blanc

PATAS / LEGS / PIEDS

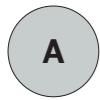

Aluminio
Aluminium / Aluminium



Haya
Beech / Hêtre

Detalles Details / Détails



Medidas Measures / Mesures

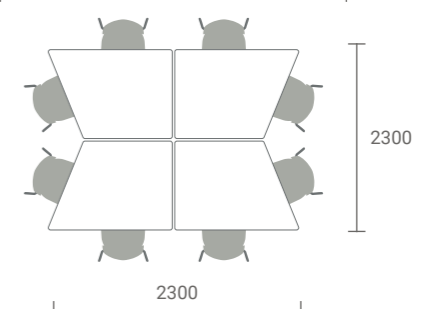
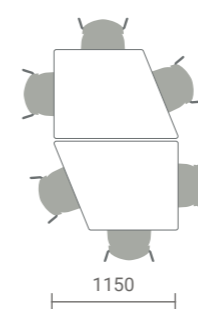
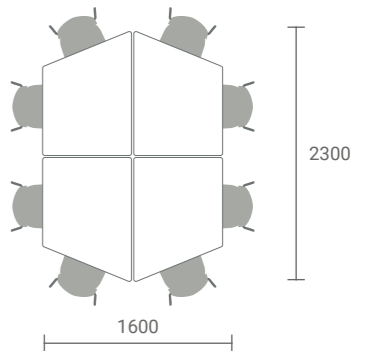
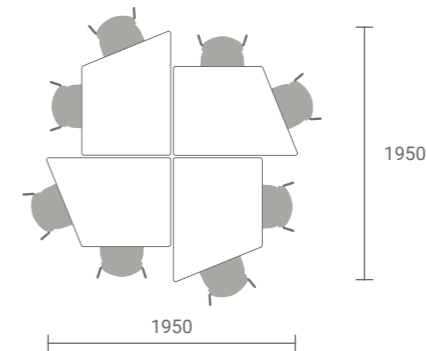
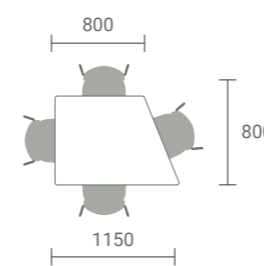
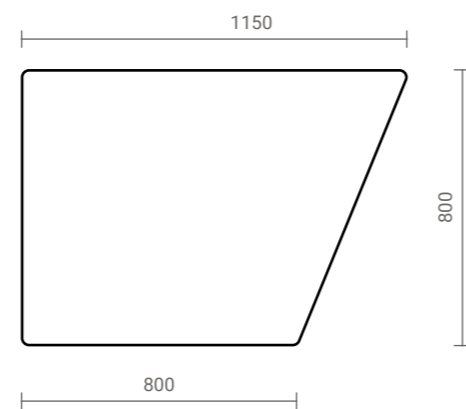

DIAMOND

MODELO 152

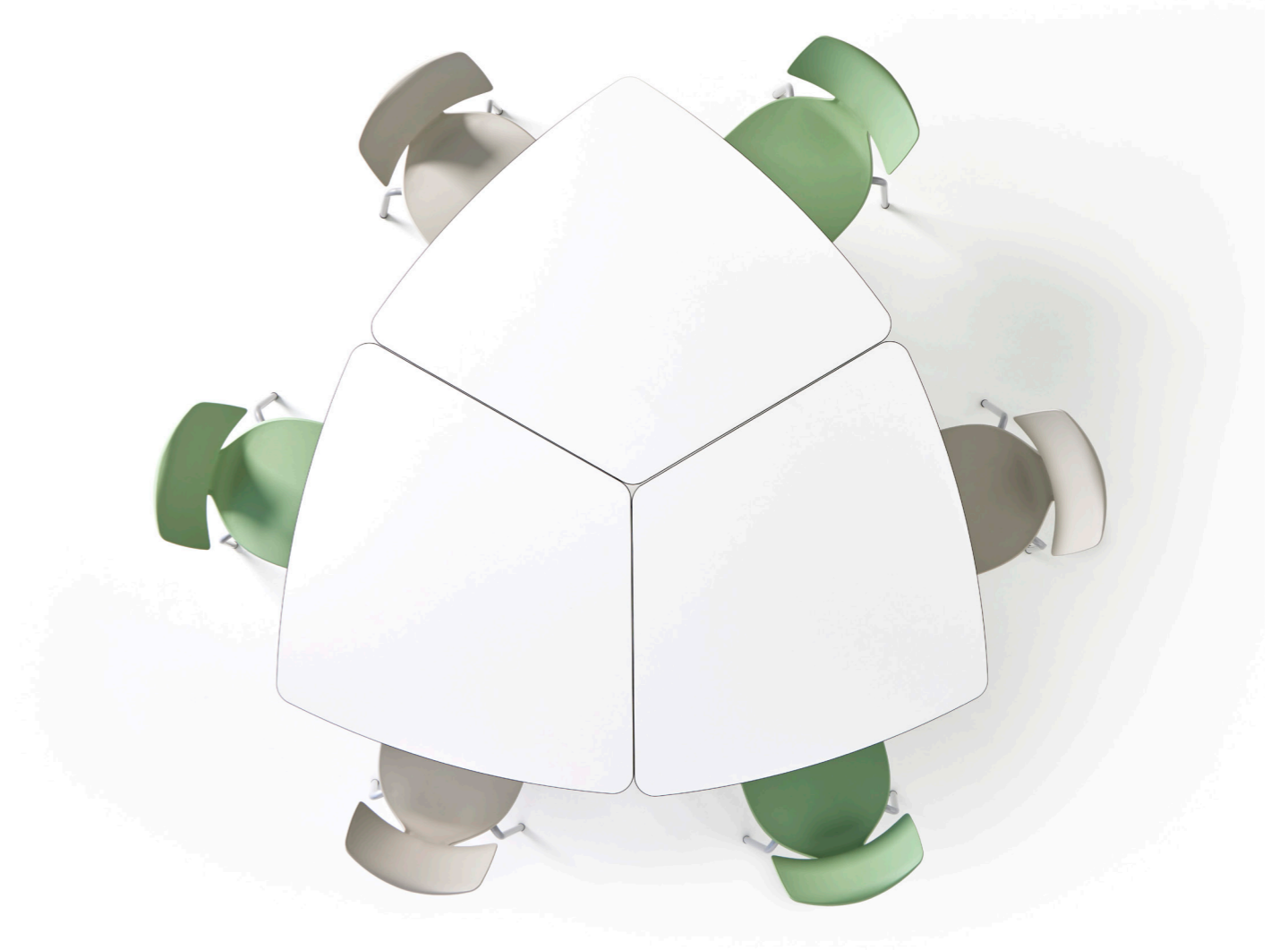

Acabados Finishes / Finitions

MADERA / WOOD / BOIS



Blanco
White / Blanc

PATAS / LEGS / PIEDS



Aluminio
Aluminium / Aluminium



Haya
Beech / Hêtre

Detalles Details / Détails



Medidas Measures / Mesures

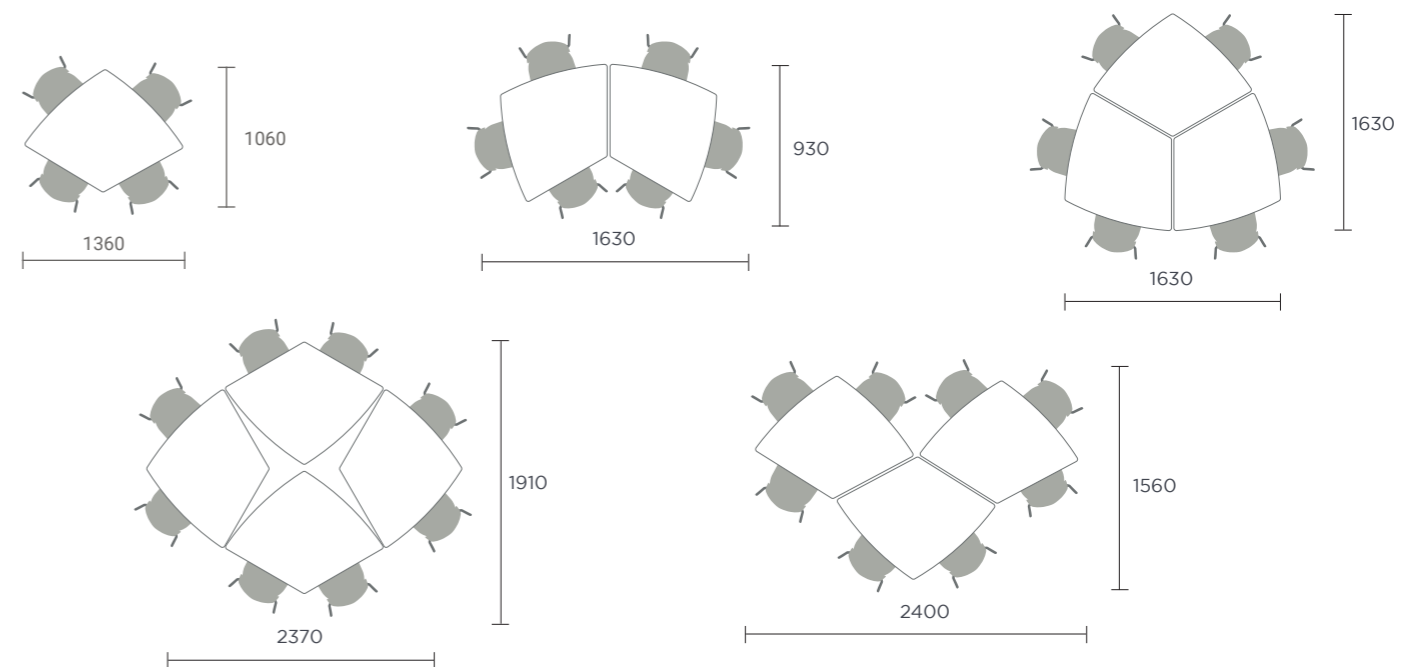
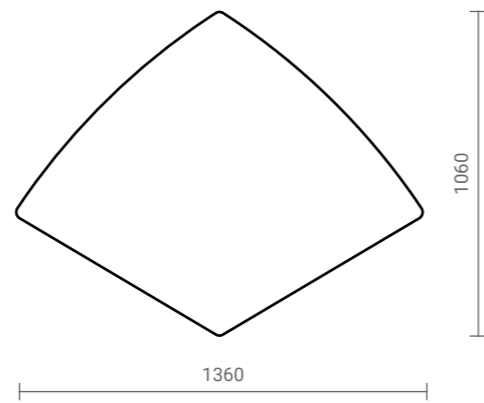



LOOP

MODELO 153

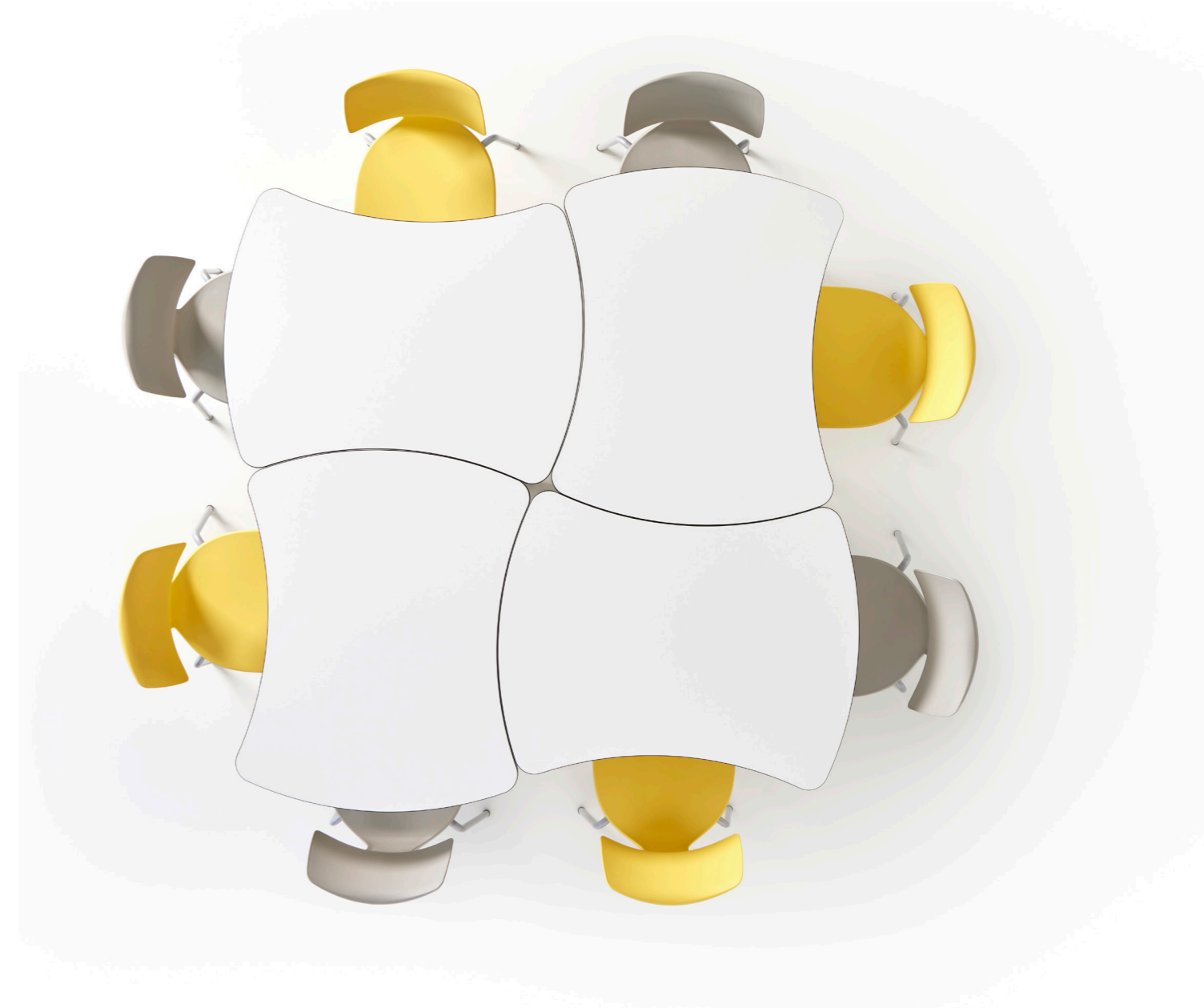

Acabados

Finishes / Finitions

MADERA / WOOD / BOIS



Blanco
White / Blanc

PATAS / LEGS / PIEDS



Aluminio
Aluminium / Aluminium



Haya
Beech / Hêtre

Detalles

Details / Détails



Medidas

Measures / Mesures

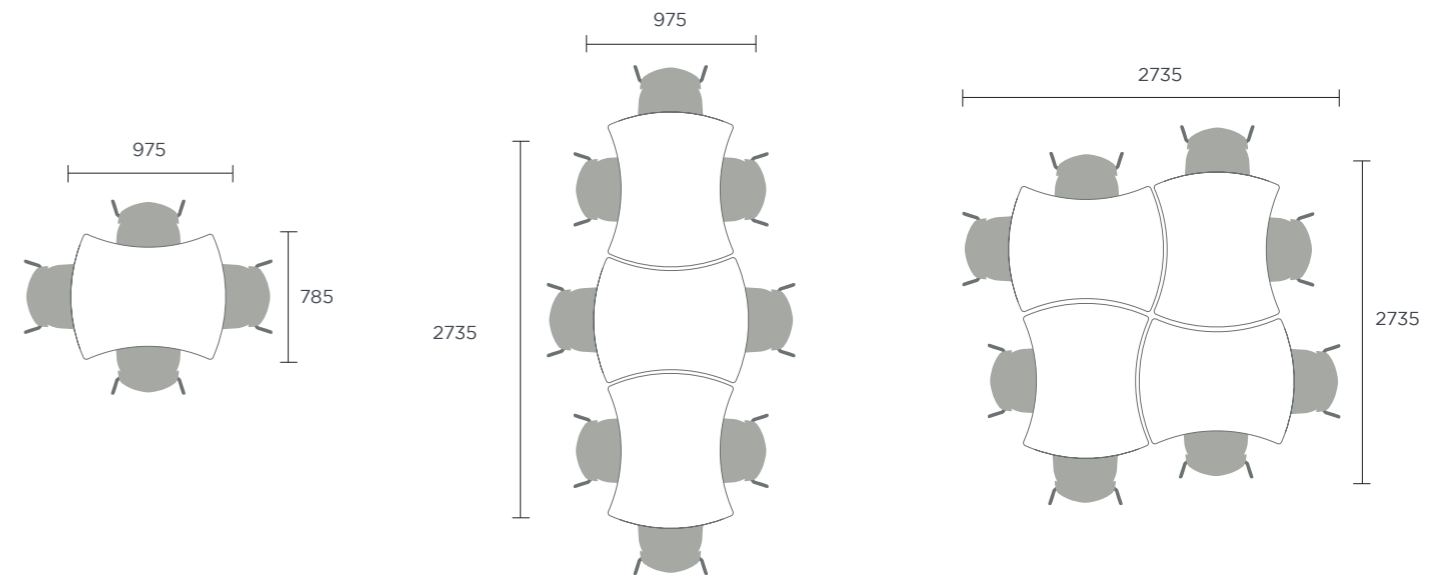
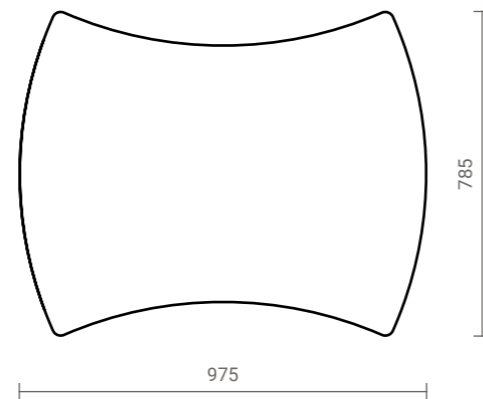



MOON

MODELO 154



Acabados

Finishes / Finitions

MADERA / WOOD / BOIS



Blanco
White / Blanc

PATAS / LEGS / PIEDS



Aluminio
Aluminium / Aluminium



Haya
Beech / Hêtre

Detalles

Details / Détails



Medidas

Measures / Mesures

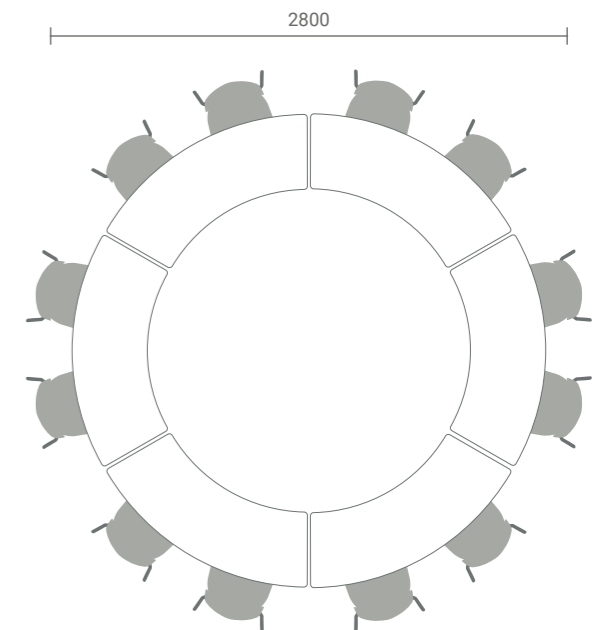
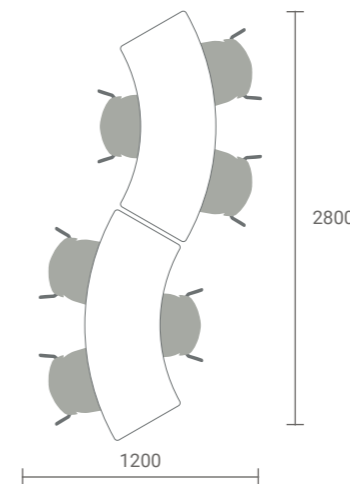
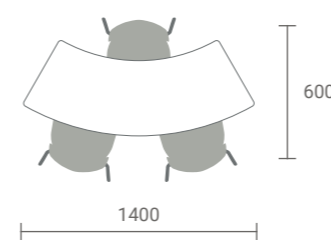
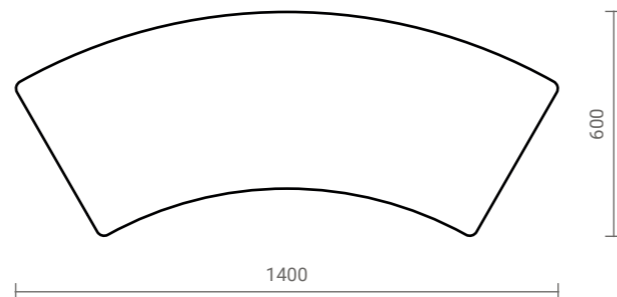

BEND

MODELO 155

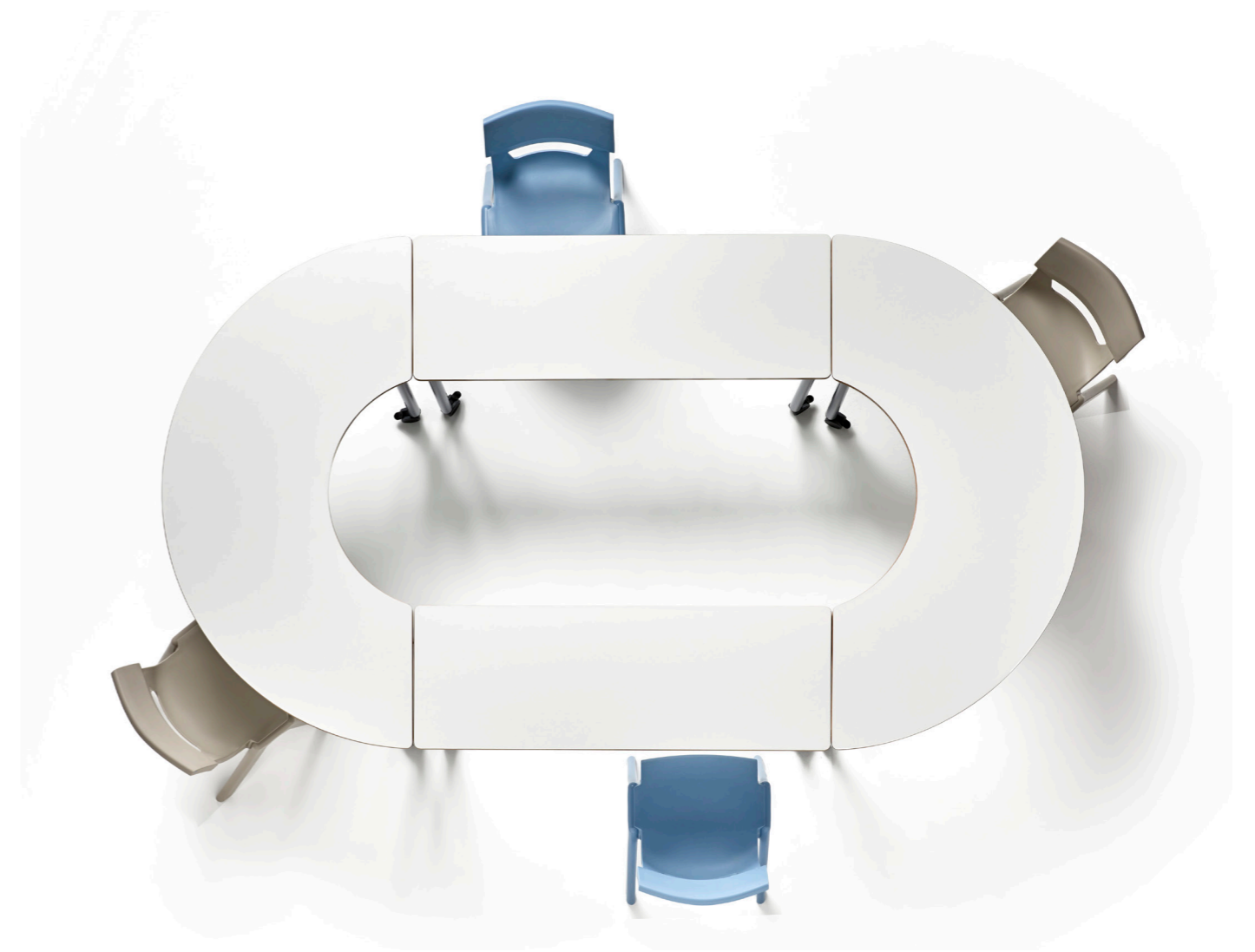

Acabados

Finishes / Finitions

MADERA / WOOD / BOIS



Blanco
White / Blanc

PATAS / LEGS / PIEDS

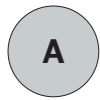

Aluminio
Aluminium / Aluminium



Haya
Beech / Hêtre

Detalles

Details / Détails



Medidas

Measures / Mesures

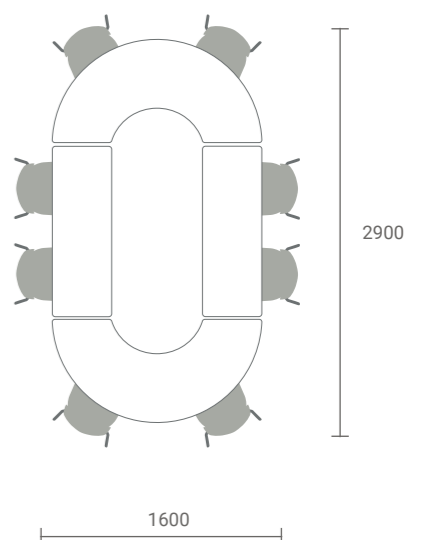
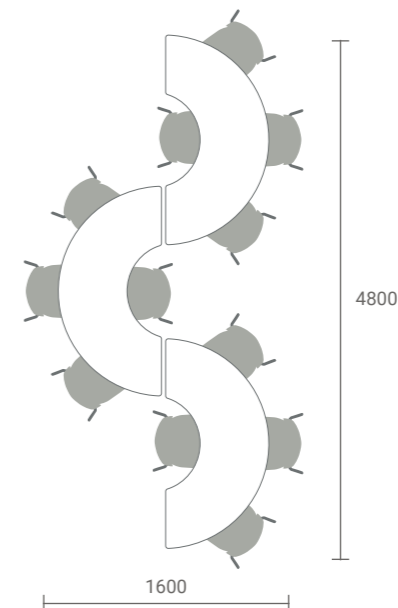
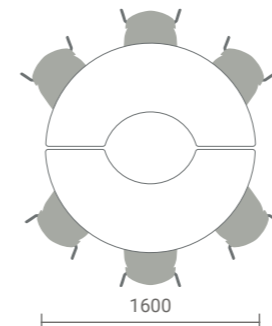
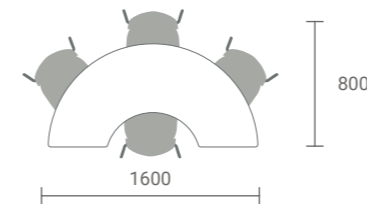
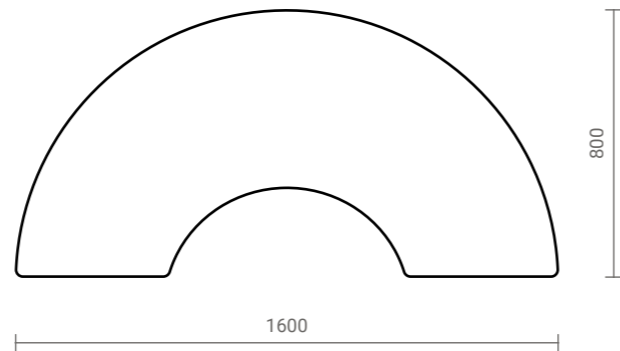



HALF

MODELO 156



Acabados

Finishes / Finitions

MADERA / WOOD / BOIS



Blanco
White / Blanc

PATAS / LEGS / PIEDS



Aluminio
Aluminium / Aluminium



Haya
Beech / Hêtre

Detalles

Details / Détails



Medidas

Measures / Mesures

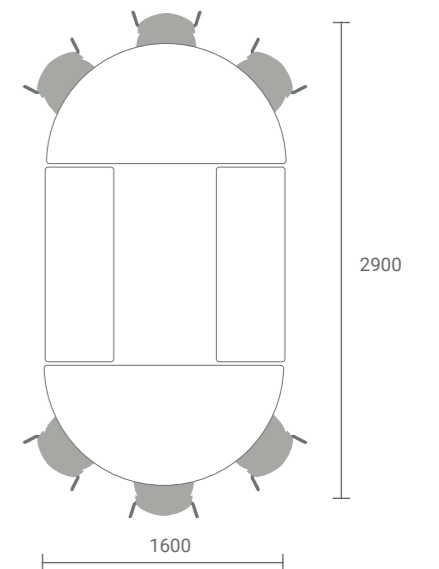
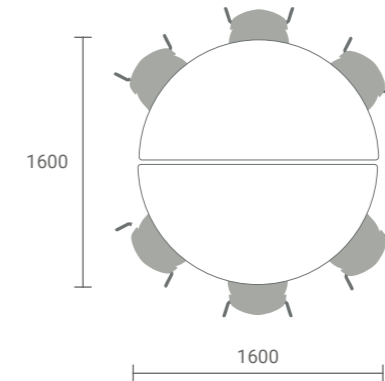
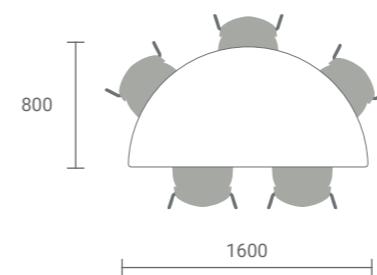
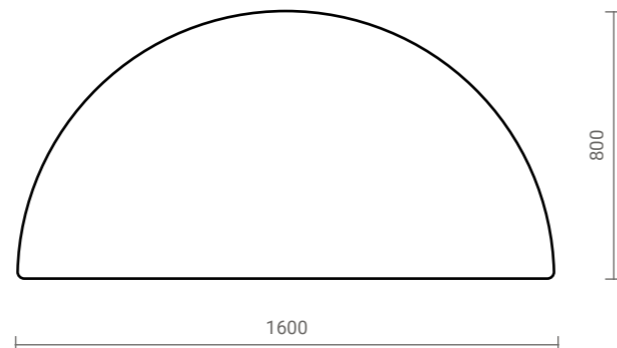

MOPAC

MODELO 158

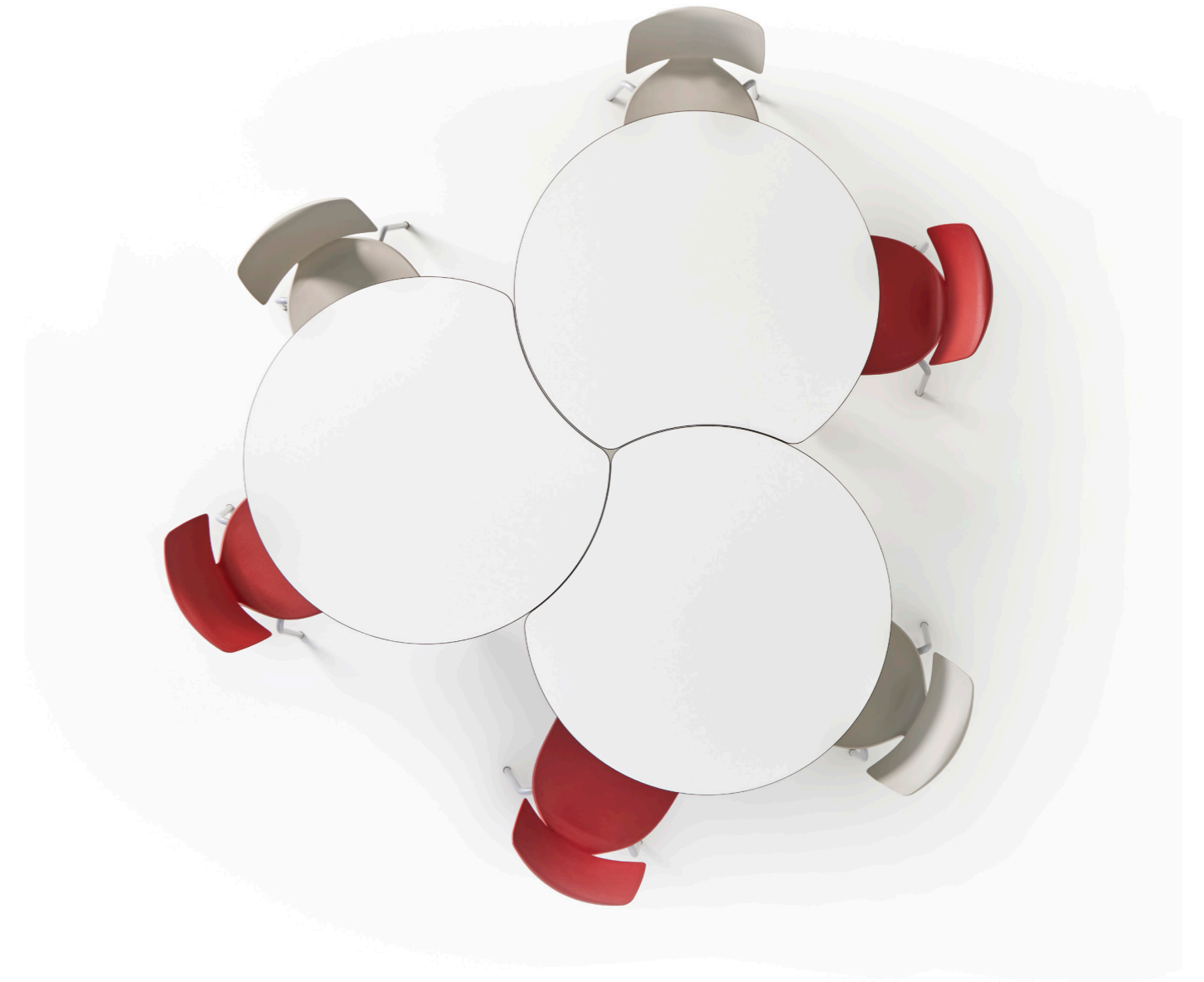

Acabados Finishes / Finitions

MADERA / WOOD / BOIS



Blanco
White / Blanc

PATAS / LEGS / PIEDS



Aluminio
Aluminium / Aluminium



Haya
Beech / Hêtre

Detalles Details / Détails



Medidas Measures / Mesures

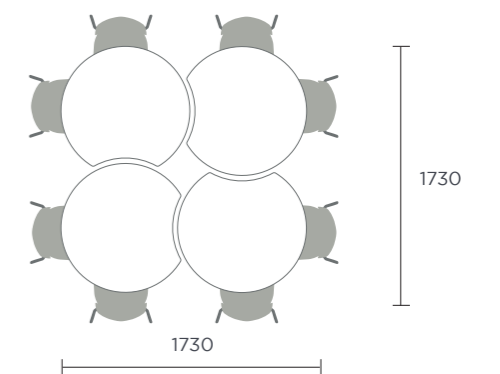
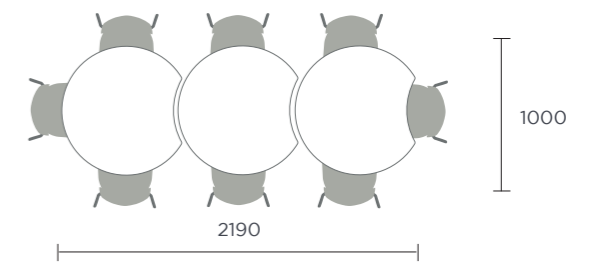
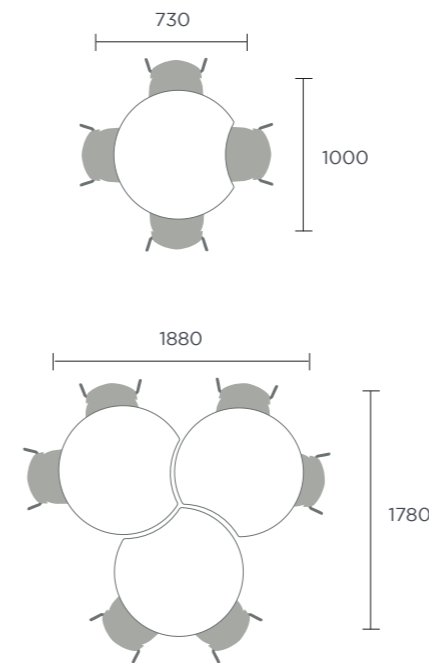
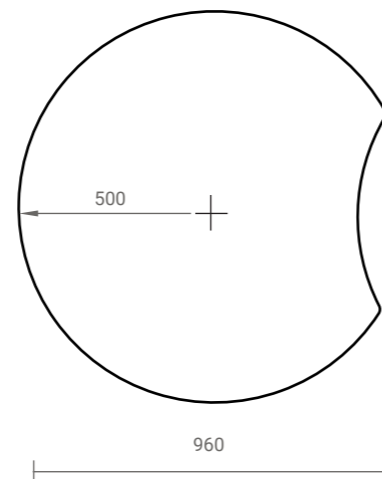



YANG

MODELO 162

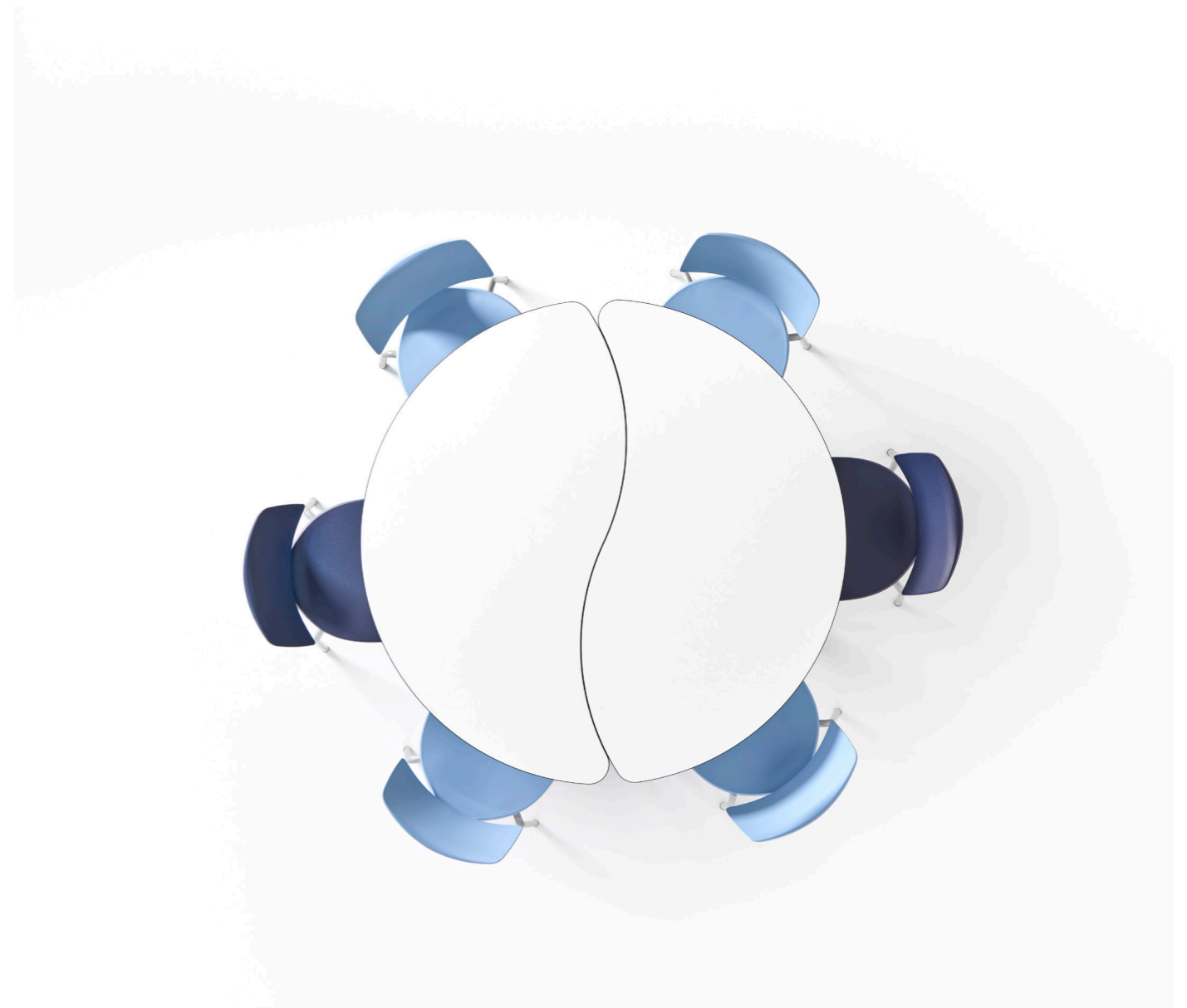

Acabados

Finishes / Finitions

MADERA / WOOD / BOIS



Blanco
White / Blanc

PATAS / LEGS / PIEDS



Aluminio
Aluminium / Aluminium



Haya
Beech / Hêtre

Detalles

Details / Détails



Medidas

Measures / Mesures

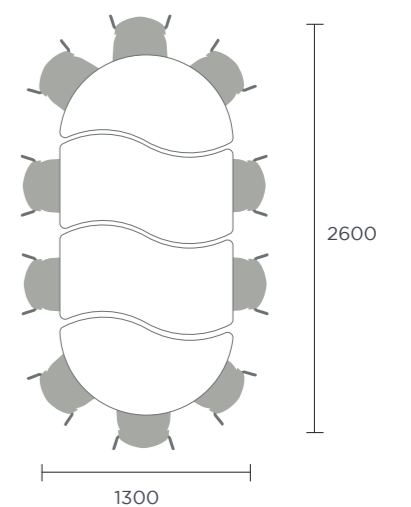
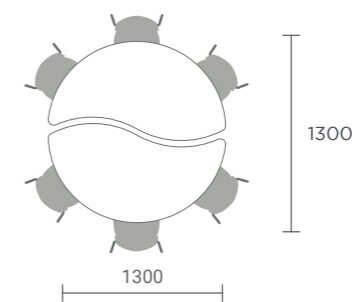
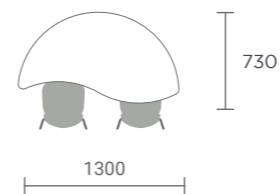
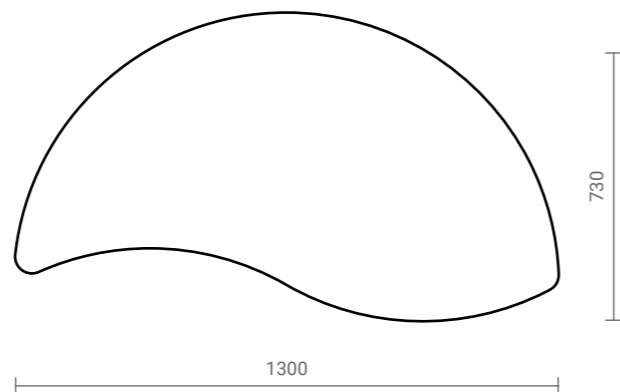

OLA

MODELO 161

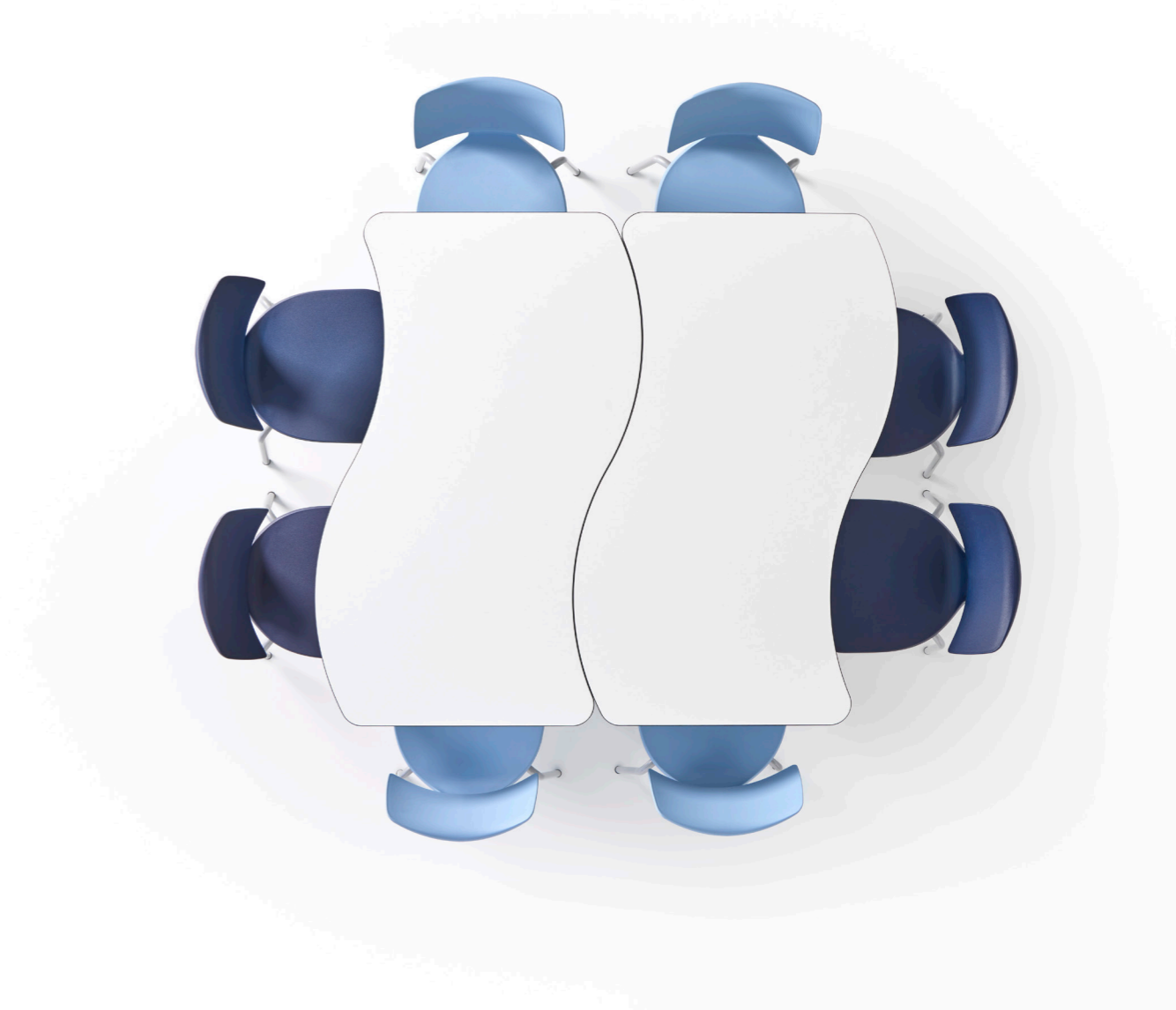
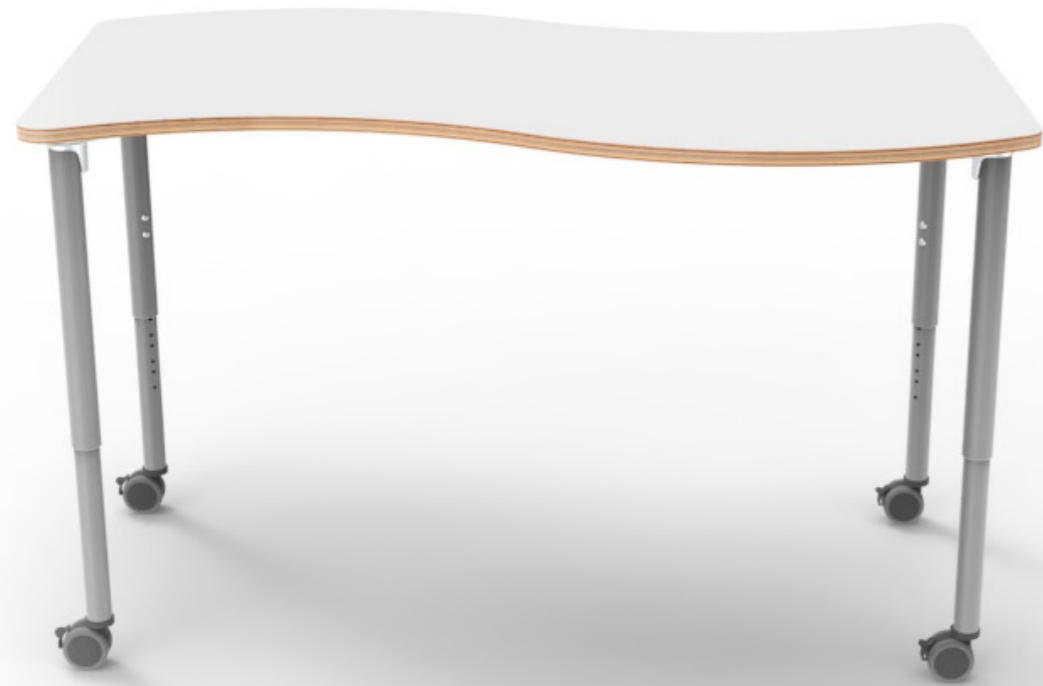

Acabados

Finishes / Finitions

MADERA / WOOD / BOIS



Blanco
White / Blanc

PATAS / LEGS / PIEDS



Aluminio
Aluminium / Aluminium



Haya
Beech / Hêtre

Detalles

Details / Détails



Medidas

Measures / Mesures

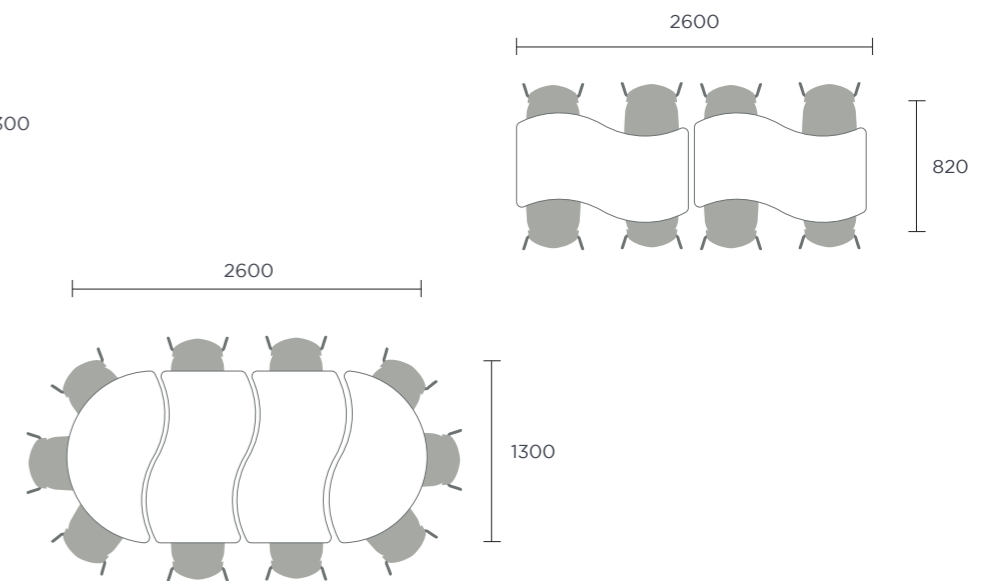
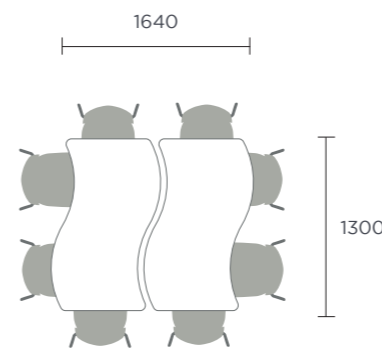
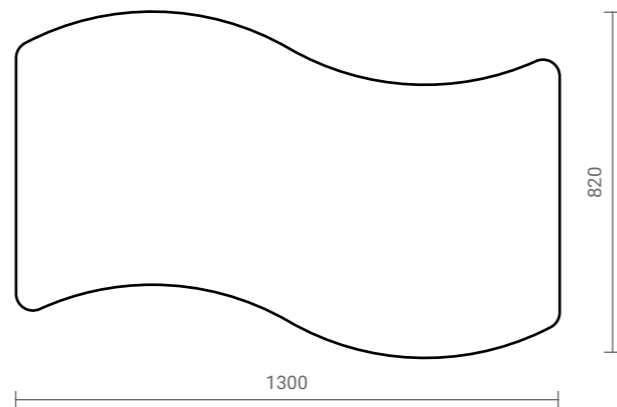



3-4-5

MODELO 345

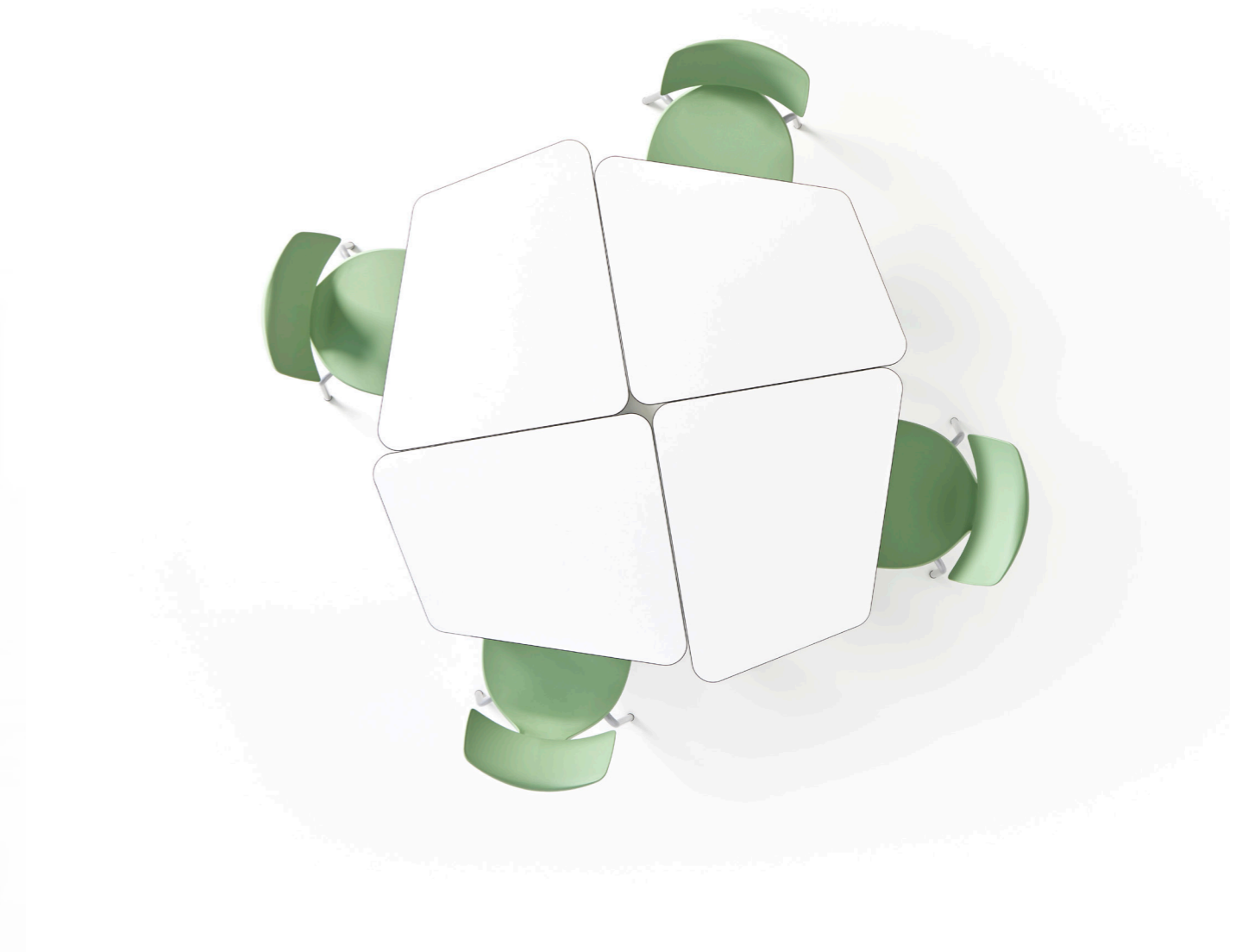

Acabados

Finishes / Finitions

MADERA / WOOD / BOIS



Blanco
White / Blanc

PATAS / LEGS / PIEDS



Aluminio
Aluminium / Aluminium



Haya
Beech / Hêtre

Detalles

Details / Détails



Medidas

Measures / Mesures

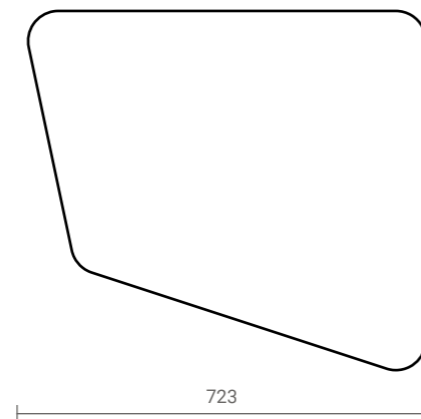

1460



658

1340

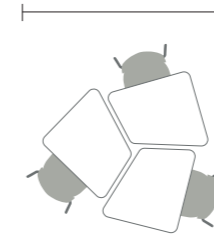

1340

1400

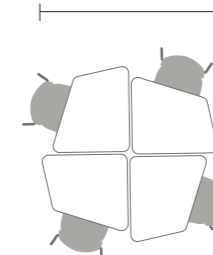

1400

1860

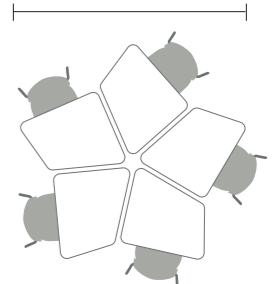

1800





CARACTERÍSTICAS / FEATURES / CARACTÉRISTIQUES

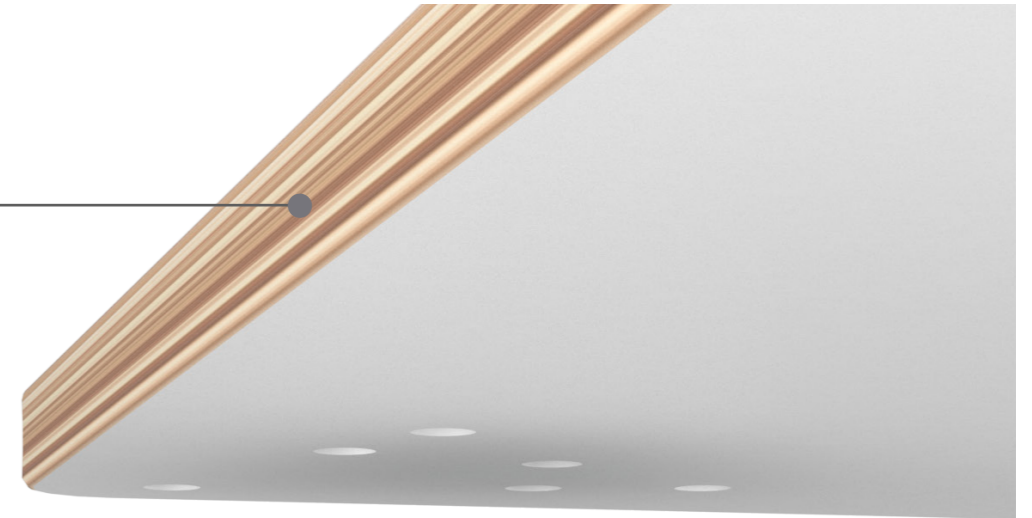

ES
Tapa Premium o Tapa Basic.

EN
Premium Lid or Basic Lid.

FR
Couvercle Premium ou Couvercle Basic.



ES
Peana inyectada en aluminio*.

EN
Aluminium injected base*.

FR
Base en aluminium injecté*.

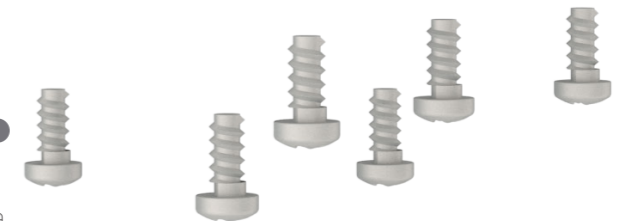

ES
Componentes para una mejor y más segura sujeción al tablero.

EN
Components for a better and safer grip on the board.

FR
Composants pour une fixation plus efficace et plus sûre au tableau de bord.



ES
Pata de tubo de acero, también disponible en madera.

EN
Steel tube leg, also available in wood.

FR
Pied en tube d'acier, également disponible en bois.

* Modelo patentado a nivel comunitario.
/ Patented model at community level. /
Modèle basé sur un modèle communautaire.

TAPA BASIC/ BASIC COVER / COUVERTURE DE BASE



ES

Tablero bilaminado, canteado en PVC 2mm color negro. Espesores de tablero de 25mm.

EN

Bi-laminated board, edged in black PVC 2mm. Board thickness 25mm.

FR

Panneau bi-laminé, bordé de PVC noir 2mm. Epaisseur du panneau : 25 mm.

PATA METÁLICA / METALLIC LEG / JAMBE METALLIQUE



ES

Tubo de acero de 40x1,5 mm y 35x2 mm. Pintada en epoxy. Tallas 1 y 2. Pata fija. Rueda o nivelador. Tallas de 3 a 6. Pata regulable. Rueda o nivelador.

EN

Steel tube 40x1,5 mm and 35x2 mm. Epoxy painted. Sizes 1 and 2. Fixed leg. Wheel or leveller. Sizes 3 to 6. Adjustable leg. Wheel or leveller.

FR

Tube d'acier 40x1,5 mm et 35x2 mm. Peinture époxy. Tailles 1 et 2. Pieds fixes. Roue ou niveleur. Tailles 3 à 6. pied réglable. Roue ou niveleur.

TAPA PREMIUM/ PREMIUM COVER / COUVERTURE PREMIUM



ES

Tablero con superficie HPL (laminado de alta presión) en ambas caras, con núcleo en contrachapado de madera de abedul, en espesores de 20/25mm y 30mm biselado. (Tablero para uso intensivo en espacios públicos).

EN

Board with HPL (high pressure laminate) surface on both sides, with birch plywood core, in thicknesses of 20/25mm and 30mm bevelled (board for intensive use in public spaces).

FR

Panneau avec surface HPL (high pressure laminate) sur les deux faces, avec âme en contreplaqué de bouleau, en épaisseurs de 20/25mm et 30mm biseauté (panneau pour usage intensif dans les espaces publics).

PATA MADERA / WOODEN LEG / PIED DE BOIS



ES

Madera maciza de haya. 40 mm. Lacada. Pata fija. Tallas 1, 2, 3, 4, 5 y 6. Sólo nivelador.

EN

Solid beech wood. 40 mm. Lacquered. Fixed leg. Sizes 1, 2, 3, 4, 5 and 6. Wheel or leveller.

FR

Bois de hêtre massif. 40 mm. Laqué. Pieds fixes. Tailles 1, 2, 3, 4, 5 et 6. Roulette ou niveleur.

FICHA TÉCNICA / DATA SHEET / FICHE TECHNIQUE

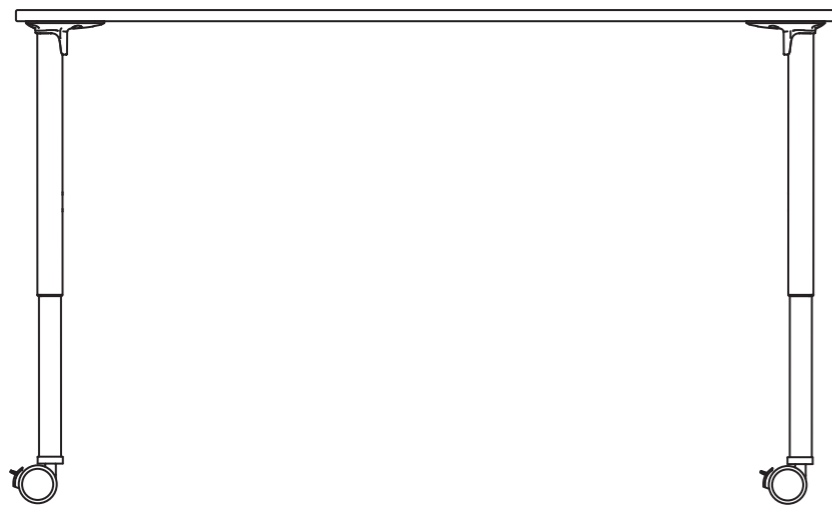

	T6	765 ± 2 mm
	T5	700 ± 2 mm
	T4	650 ± 2 mm
	T3	600 ± 2 mm
	T2	530 ± 2 mm
	T1	460 ± 2 mm

ES Descripción:
Mesas modulares con diferentes formas y patas con ruedas para aportar una mayor y mejor movilidad. Diseñadas para usos grupales y múltiples.

EN Description:
Modular tables with different shapes and legs with wheels for greater and better mobility. Designed for group and multiple uses.

FR Description:
Tables modulaires de différentes formes et pieds à roulettes pour une meilleure mobilité. Conçues pour les groupes et les usages multiples.

- Componentes, materiales:**
- Perna en aluminio inyectado.
 - Patas: Tubo de acero o madera (Más información en página 47)
 - Tapa: Premium o Basic (Más información en página 46)

- Components, materials:**
- Die-cast aluminium base.
 - Legs: Steel tube or wood (More information on page 47).
 - Top: Premium or Basic (More information on page 46)

- Components, materials:**
- Base en aluminium moulé sous pression.
 - Pieds : tube d'acier ou bois (Plus d'informations à la page 47).
 - Plateau : Premium ou Basic (Plus d'informations à la page 46)

- Características principales:**
- Robusta.
 - Desmontable (se sirve desmontada).
 - Modular.
 - Aulas multiusos.
 - Opción ruedas o niveladores
 - Opción de rejilla o gavetas plásticas.

- Main characteristics:**
- Robust.
 - Detachable (is served disassembled).
 - Modular.
 - Multipurpose rooms.
 - Option of castors or levellers
 - Option of grille or plastic drawers.

- Main characteristics:**
- Robuste.
 - Détachable (livré démonté).
 - Modulaire.
 - Salles de classe polyvalentes.
 - Option de roulettes ou de niveleurs.
 - Possibilité de grille ou de tiroirs en plastique.

Pata / Leg/ pieds:



Tablero/ Top/ Tapeau:



Opciones / Options/ Options:

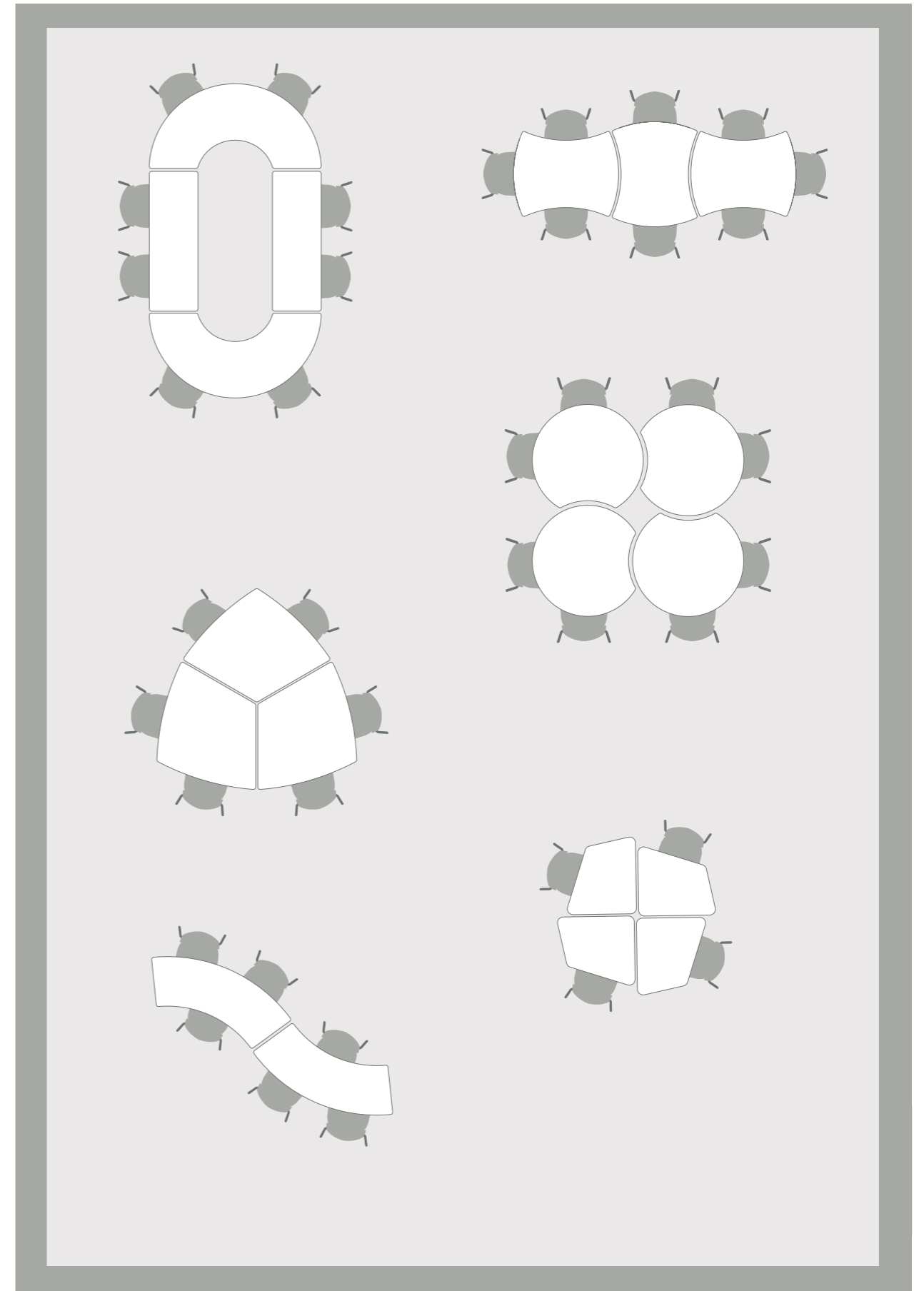

Ecodiseño

Actiflex Tables

Modelo	Peso	Volumen	Materiales	Producción	Transporte Cartón y tintas sin disolvente	Uso Mantenimiento, reparación y limpieza	Eliminación Reciclabilidad
	X kg		Alto	100%	100%	Muy Fácil	Alto
	X kg		Alto	100%	100%	Muy Fácil	Alto
	X kg		Alto	100%	100%	Muy Fácil	Alto
	X kg		Alto	100%	100%	Muy Fácil	Alto
	X kg		Alto	100%	100%	Muy Fácil	Alto

Ecodiseño

Actiflex Tables

Modelo	Peso	Volumen	Materiales	Producción	Transporte Cartón y tintas sin disolvente	Uso Mantenimiento, reparación y limpieza	Eliminación Reciclabilidad
	X kg		Alto	100%	100%	Muy Fácil	Alto
	X kg		Alto	100%	100%	Muy Fácil	Alto
	X kg		Alto	100%	100%	Muy Fácil	Alto

Materiales: Utilización de materiales con alto índice de reciclabilidad. Optimización máxima de las materias primas para reducir residuos y consumo de energía.

Producción: Máxima optimización del uso energético desde el diseño. Optimización de procesos. Reducción de vertidos y residuos.

Transporte: Optimización del transporte con diseños desmontables. Embalajes reducidos y con Tintas de impresión en embalajes con base de agua sin disolventes.

Uso: Calidad y garantía máxima. Mantenimientos fáciles con materiales básicos. Posibilidad de reposiciones de componentes.

Eliminación: Reducción de residuos. Fácil separación de componentes. Tintas de impresión en embalajes con base de agua sin disolventes.

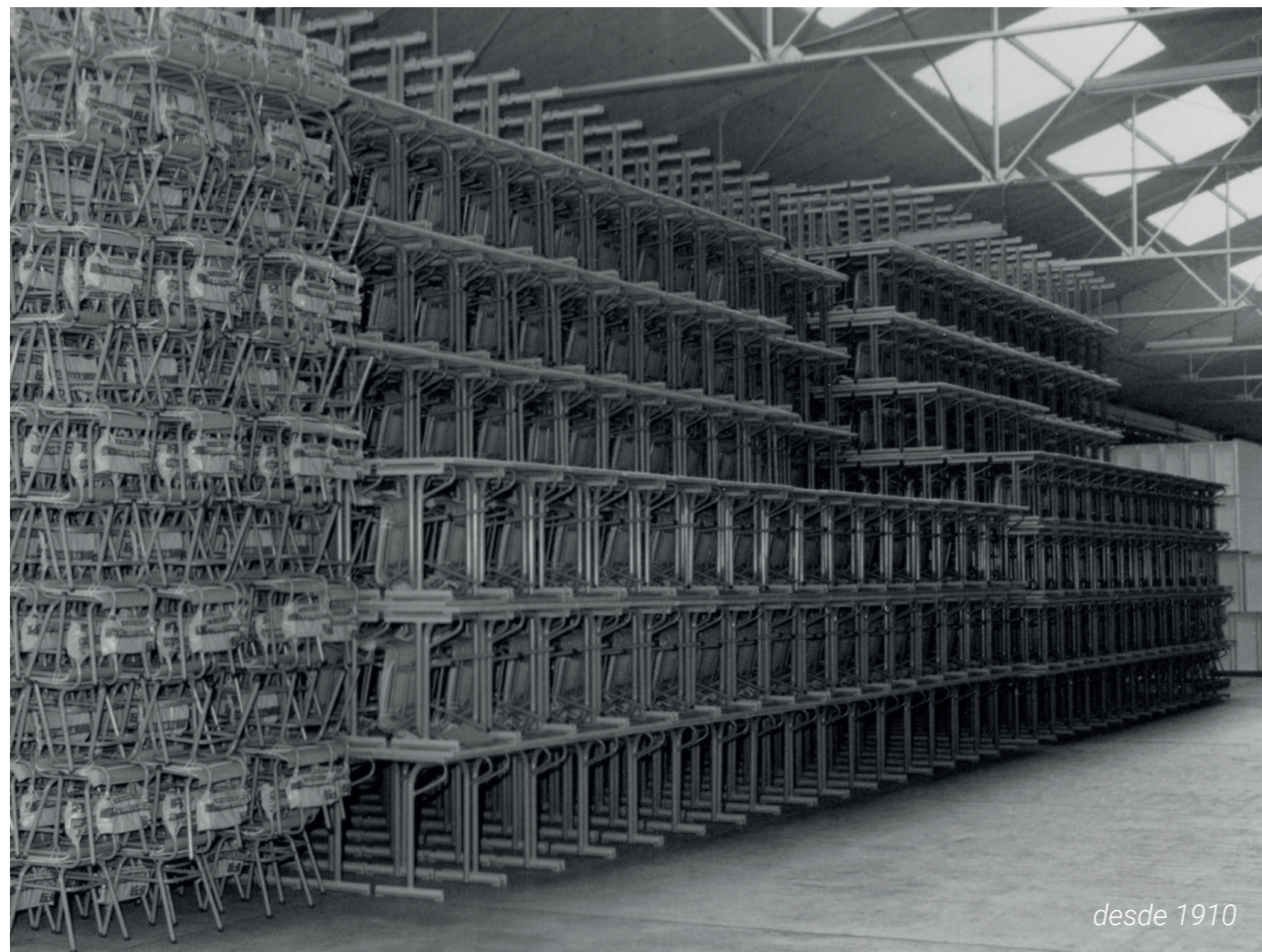

desde 1910

ES

FEDERICO GINER, empresa creada en 1910, se ha convertido en un referente en el sector de la fabricación de mobiliario escolar, instalaciones y carros portaequipajes, basándose en dos pilares fundamentales: la calidad y la innovación como características básicas de su producción.

“El diseño, la calidad, durabilidad y funcionalidad son las bases sobre la que se cimienta la empresa desde hace más de un siglo. Y como no, todo empieza con el mobiliario para los más pequeños para que puedan construir su futuro. Con todas las garantías.”

EN

FEDERICO GINER, a company created in 1910, has become a benchmark in the sector of manufacturing school furniture, facilities and baggage carts, based on two fundamental pillars: quality and innovation as basic features of its production.

“Design, quality, durability and functionality are the foundations on which the company has been built for more than a century. And of course, it all starts with furniture for the little ones so that they can build their future. With all the guarantees.”

FR

FEDERICO GINER, société créée en 1910, est devenue une référence dans le secteur de la fabrication du mobilier scolaire, collectivités et chariots à bagages, fondée sur deux piliers: la qualité et l'innovation comme caractéristiques de base de sa production.

“Le design, la qualité, la durabilité et la fonctionnalité sont les fondations sur lesquelles la société s'est construit depuis plus d'un siècle. Et bien sûr, tout commence par le mobilier pour les plus petits afin pour qu'ils puissent construire leur avenir. Et avec toutes les garanties”



DISEÑADOR / DESIGNER / CONCEPTEUR

Marcelo Alegre · Alegre Design

“ Rediseñadas por Alegre Design, la colección de sillas Master Pro de Federico Giner es todo lo que un espacio necesita para disfrutar de la comodidad, del diseño y de la elegancia. ”

“ Redesigned by Alegre Design, the Master Pro chair collection by Federico Giner is everything a space needs to enjoy comfort, design and elegance. ”

“ Redessinée par Alegre Design, la collection de chaises Master Pro de Federico Giner est tout ce dont un espace a besoin pour profiter du confort, du design et de l'élégance. ”

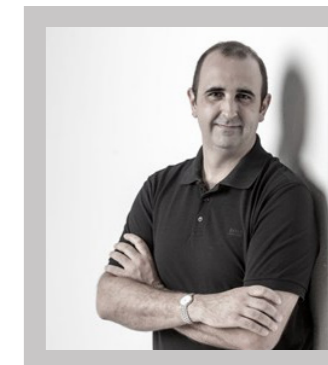



BROCHURE 2023
RV.08/23

Ctra. Liria-Tavernes, s/n Esquina C/Portalet
46760 Tavernes de la Vallidigna (Valencia)
T. 96 282 40 50 - M. 608 218 939
info@federicoginer.com
www.federicoginer.com



BROCHURE 2023
RV.08/23

Ctra. Liria-Tavernes, s/n Esquina C/Portalet
46760 Tavernes de la Vallidigna (Valencia)
T. 96 282 40 50 - M. 608 218 939
info@federicoginer.com
www.federicoginer.com