

# FEDERICO GINER



## École Française - Classe 13

Aujourd'hui - Salutations

- Bonjour - hello
- Comment ça va? - how are you?
- Salut! - hi!
- Comment tu l'appelle? - what is your name?
- Au revoir - goodbye
- enchanse - nice to meet you

programme Semaine

- où est la capitale?
- quand se passe le tour?
- quelle est la langue officielle?

avec carte  
avec un drapeau  
avec un produit  
avec un animal  
avec un plat

avec carte  
avec un drapeau  
avec un produit  
avec un animal  
avec un plat

- To Do CATALINA NUNE MEXER
- \* Confirm flights
  - \* Book leave
  - \* write guest list

CATÁLOGO



FEDERICO GINER  
desde 1910



# Contenido

## Content

- 01 Why FG?
- 02 Spaces
- 03 Products
- 04 Size Guide
- 05 Finishes

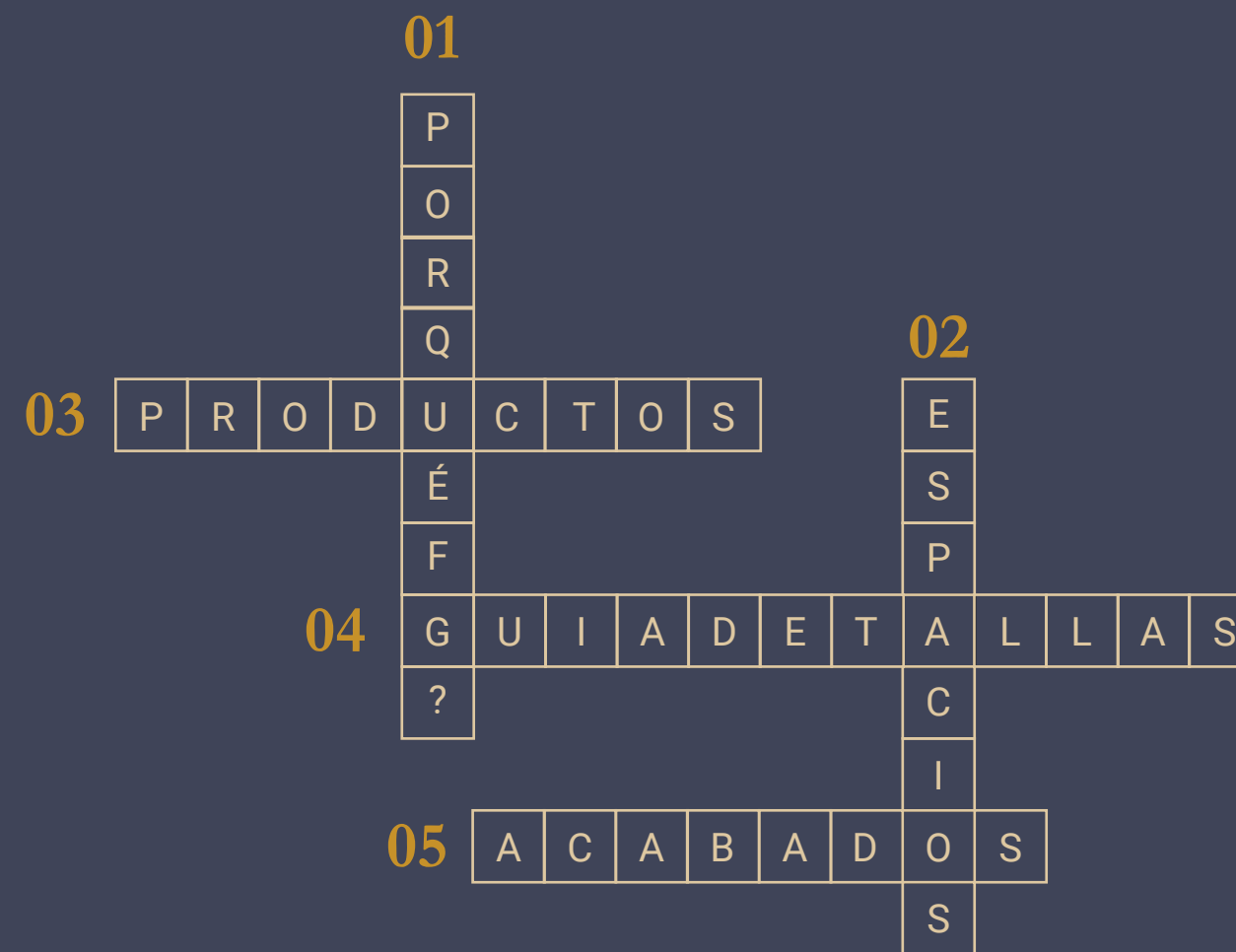



# 01

P	T	B	C	B	O	P	V	L	C	O	E	L	O
C	Y	O	<b>P</b>	A	Ñ	C	K	W	B	A	Q	E	A
Q	C	Ñ	<b>O</b>	Ñ	W	Q	C	D	R	K	S	Z	K
R	N	B	<b>R</b>	P	T	R	A	N	X	Y	T	K	Y
Y	X	O	<b>Q</b>	A	B	Y	M	O	P	R	Y	O	R
C	U	M	<b>U</b>	X	W	C	T	P	Y	A	N	E	A
L	Ñ	B	<b>É</b>	Z	B	L	Ñ	V	U	I	L	P	I
C	P	I	<b>F</b>	T	L	C	L	N	Z	Ñ	A	P	Ñ
C	Q	H	<b>G</b>	A	B	C	A	G	X	J	W	E	J
C	Y	G	<b>?</b>	B	V	C	C	H	L	K	P	L	K
C	L	I	C	R	Q	C	O	K	R	L	W	C	L
M	Y	K	C	E	Z	M	P	B	W	M	V	P	M



**FEDERICO GINER**, una marca ligada a la historia de la educación en España en los últimos cien años, se ha convertido en todo un referente en el sector de la educación, tanto a nivel nacional como internacional, ya que ha sabido reinventarse para hacer frente a las demandas y necesidades de un mundo cada vez más cambiante. Y es que, la flexibilidad en el diseño, la producción y el testeo de sus productos, han hecho de FEDERICO GINER una marca que se ha convertido en sinónimo de máxima calidad y trabajo bien hecho.

**FEDERICO GINER**, a brand linked to the history of education in Spain in the last hundred years, has become a benchmark in the education sector, both nationally and internationally, and to which has managed to reinvent itself to cope to the demands and needs of an increasingly changing world. And is that, the flexibility in design, production and the testing of their products, have made FEDERICO GINER a brand that has become synonymous with top quality and work well done.



1910

**Federico Giner** pone en marcha el primer taller de carpintería de Tavernes de la Valldigna (Valencia), el embrión de un negocio de base industrial que actualmente es todo un referente en el sector de la fabricación de mobiliario escolar e instalaciones. Sus productos siempre se han definido por su calidad, perdurabilidad y funcionalidad.

**Federico Giner** established the first carpenter workshop in Tavernes de la Valldigna (Valencia), the birth of an industrial based business which is nowadays a benchmark in the manufacturing sector for school furniture and fixtures. Their products are renowned for their quality durability and functionality.



1975

**Llega la homologación escolar**  
*The school endorsement arrives*

El Ministerio de Educación crea una nueva normalización en la fabricación del mobiliario escolar que la empresa aborda de manera inmediata. Al mismo tiempo, consolida su presencia internacional a través de ferias y certámenes por todo el mundo.

*The Ministry of Education introduces new regulations to school furniture production which the company immediately adopts. At the same time the company's international presence is consolidated by participating in international fairs and tenders.*



1992

**Colaboración con Institutos Tecnológicos**  
*Collaboration with technological institutions*

Se inicia una estrecha relación con AIDIMA e IBV de Valencia, con el objetivo de no cesar en la investigación y desarrollo en el mobiliario escolar. En estos años, se amplía la oferta con el mueble para Universidad y la fabricación de carros portaequipajes en aeropuertos.

*A close line of communication is formed with Valencia AIDIMA and IBV with the aim of continuous research and development of school furniture. During this period the range of products is expanded to include university furniture and airport trolleys.*



1926

**Especialización por el mobiliario escolar**  
*Specializing in school furniture*

Comienza la participación de Federico Giner en las convocatorias de concursos para suministro de muebles escolares del Ministerio de Educación, un hecho que marcará la especialización de la firma y su trayectoria.

Federico Giner starts tendering for school furniture contracts with the Ministry of Education, an event which marks the beginning of specialization in the company and its industrial projection.



1989

**El nacimiento de un parque empresarial**  
*The birth of a business park*

Con el crecimiento de la empresa, se construyen nuevas instalaciones y se crea una red de empresas auxiliares que configuran un tejido industrial alrededor de la firma. Esta se apoya en la colaboración de diseñadores externos que aportan un toque de frescura al mobiliario de hogar y educativo.

*With the growth of the company, new installations are constructed and an auxiliary network of companies is created, which forms an industrial web around the company. This is supported by the collaboration of external designers who bring a fresh approach to school and household furniture design.*



2023

**Un nuevo enfoque**  
*A new approach*

Federico Giner apuesta por la innovación y la internacionalización. Lanzamiento de nuevo catálogo, fruto de constantes inversiones durante los últimos 5 años en colaboración con prestigiosos diseñadores. El objetivo de los próximos años es estar presente en ferias internacionales y seguir innovando con el fin de dar a conocer los valores y atributos de los productos FG fuera de nuestras fronteras.

*Federico Giner is committed to innovation and internationalization. Launch of a new catalog, the result of constant investments over the past 5 years in collaboration with prestigious designers. The objective of the coming years is to be present at international fairs and to continue innovating in order to the values and attributes of FG products outside our borders.*

## Calidad Federico Giner

Una inversión en productos FG, es una inversión en calidad que ha sido probada a lo largo de los años y que es respaldada con garantías comprobadas.

Factores a tomar en cuenta:

- Funcionalidad del producto en relación a la necesidad a cubrir.
- Medidas adecuadas al usuario según normativa.
- Acabados y materiales para uso intensivo en espacio públicos.
- Mantenimientos y garantía de reposición.

An investment in FG products, is an investment in quality that has been proven over the years and is backed with proven warranties.

Factors to take into account:

- Functionality of the product in relation to the need to be covered.
- Adequate measures to the user according to regulations.
- Finishes and materials for intensive use in public spaces.
- Maintenance and replacement guarantee.

FEDERICO GINER  
desde 1910



**Fabricado en España**  
*Made in Spain*



**Productos diseñados según normativa Europea**  
*Products certified with European standards*



**Fabricación de calidad**  
*Quality manufacturing*

### Garantía FG *Warranty*



**Pupitres y colección Postura+**  
Desks and Postura+ collection



**Mesas y sillas**  
Tables and chairs



**Productos móviles**  
Mobile products



**Otras empresas**  
Other companies



**Proveedor oficial**  
*Official supplier*

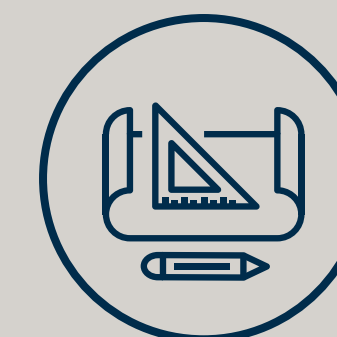

**Diseño de aulas y proyectos personalizados**  
*Classroom design and customized projects*



**Servicio rápido de entrega**  
*Quick ship delivery*



\*Consultar más información sobre garantía de cada producto en : [info@federicoginer.com](mailto:info@federicoginer.com)  
\*Consult more information on the warranty of each product at [info@federicoginer.com](mailto:info@federicoginer.com)

## Visión general de productos



**DIDA Classic**  
p.65



**DIDA Confort**  
p.65



**DIDA Pad 360**  
p.66



**DIDA Pad**  
p.66



**DIDA Wood**  
p.68



**DIDA Active**  
p.68



**DIDA Basket**  
p.69



**DIDA Move**  
p.69



**Meet Classic**  
p.72



**Meet Confort**  
p.72



**Meet Skate**  
p.72



**Meet Cantilever**  
p.75



**Meet Move**  
p.75



**Meet Basket**  
p.75



**Silla Postura**  
p.77



**Silla Hatton**  
p.77



**Postura wood**  
p.78



**Pad Chair**  
p.80



**Master Pro**  
p.82



**Master Pro Confort**  
p.82



**Master Pro Active**  
p.82



**Master Pro Move**  
p.83



**Master Pro Move Confort**  
p.83



**Silla Oficina**  
p.84



**Taburete DIDA**  
p.71



**Taburete DIDA Confort**  
p.71



**Taburete Meet**  
p.73

## Products Overview



**Taburete Chambo**  
p.76



**Taburete c postura wood**  
p.78



**Taburete a postura wood**  
p.78



**Taburete c postura**  
p.79



**Taburte a postura**  
p.79



**Taburete c postura move**  
p.79



**Taburete a postura move**  
p.79



**Mesa Loop**  
p.88



**Mesa Diamond**  
p.88



**Mesa Yang**  
p.90



**Mesa Ola**  
p.90



**Mesa Mopac**  
p.92



**Mesa Half**  
p.92



**Mesa Moon**  
p.93



**Mesa Kite**  
p.93



**Mesa Bend**  
p.94



**Mesa Link**  
p.94



**Mesa Tutor**  
p.97



**Mesa Tutor Ágil**  
p.97



**Mesa Profesor**  
p.98



**Mesa Modular**  
p.99



**Mesa Ágil**  
p.100



**Mesa Living Alta**  
p.104



**Mesa Living Circular**  
p.104



**Mesa Living Alta**  
p.105



**Mesa Living Rectangular**  
p.105

## Visión general de productos



Pupitre DIDA rectangular  
p.107



Pupitre DIDA trapezoidal  
p.107



Pupitre Meet  
p.108



Pupitre rectangular Actiflex  
p.109



Pupitre trapezoidal Actiflex  
p.109



Pupitre Rectangular  
p.110



Pupitre Trapezoidal  
p.110



Pupitre FG  
p.112



Pupitre FG con rejilla  
p.112



Pupitre FG estante madera  
p.112



Pupitre Modular  
p.113



Pupitre Ágil  
p.113



Armario Recto Alto  
p.116



Armario Curvo Alto  
p.116



Armario Recto Bajo  
p.116



Armario Curvo Bajo  
p.116



Soft Seating Recto Bajo  
p.117



Soft Seating Recto  
p.117



Soft Seating Circular  
p.117



Soft Seating Curvo Bajo  
p.118



Soft Seating Curvo Alto  
p.118



Grada  
p.118



SERP Recto  
p.122



SERP Curvo Abierto  
p.122



SERP Curvo Cerrado  
p.122

## Products Overview



Mesa SERP  
p.123



Mesa Circular SERP  
p.123



Estantería baja  
p.125



Armario gavetero bajo  
p.125



Armario intermedio puertas  
p.125



Estantería intermedia  
p.125



Armario gavetero intermedio  
p.125



Estantería media  
p.125



Armario gavetero medio  
p.126



Armario medio con puertas  
p.126



Armario alto con puertas  
p.126



Estantería alta  
p.126



Armario gavetero alto  
p.126



Armario alto con puertas  
p.127



Armario super alto con puertas  
p.127



Estantería super alta  
p.126



Panel acústico cuadrado  
p.131



Panel acústico circular  
p.131



Panel acústico onda  
p.131



Panel acústico rectangular  
p.131



Panel acústico pared  
p.131



Cábina Acústica Doble  
p.131



Cábina Acústica Individual  
p.131



# 02

P T B A B O P V L C O E L O  
C Y O B A Ñ C K W B A Q E A  
Q C Ñ A Ñ W Q C D R K S Z K  
R N B **E S P A C I O S** T K Y  
Y X O S A B Y M O P R Y O R  
C U M P X W C T P Y A N E A  
L Ñ B A Z B L Ñ V U I L P I  
C P I C T L C L N Z Ñ A P Ñ  
C Q H I A B C A G X J W E J  
C Y G O B V C C H L K P L K  
C L I S R Q C O K R L W C L  
M Y K R E Z M P B W M V P M





# Aula del futuro

Future classroom lab.

PROVEEDOR OFICIAL  
aula del futuro



El aula del futuro se concibe como un espacio creativo donde el alumnado encuentra todo aquello que necesita para experimentar múltiples y diversas experiencias de aprendizaje. Contempla aulas muy versátiles, espacios abiertos, multifuncionales y con mobiliario modular móvil que permita la creación de diversas zonas. Las zonas de aprendizaje de un espacio creativo no han de ser concebidas de forma rígida, sino flexible y adaptable a cada necesidad. En muchos casos no siempre están presentes todas las zonas de forma individual, sino que pueden solaparse unas con otras en función de los medios y la necesidad, lo mismo que para los diferentes elementos tecnológicos. A continuación, se definen las zonas de aprendizaje establecidas en el modelo del aula del futuro.

**Interacción:** Equipada con una pizarra interactiva, esta zona ilustra cómo utilizar la tecnología en un aula tradicional para fomentar la interacción y la participación de los alumnos. Proporciona la oportunidad de experimentar formas de enseñanza y un aprendizaje más interactivo dentro de un entorno tradicional con la ayuda de hardware, software y contenidos específicos.

**Future classroom lab**, is conceived as a creative space where students find everything they need to experience multiple and diverse learning experiences. It envisions highly versatile classrooms, open spaces, multifunctional and with mobile modular furniture that allows the creation of different zones. The learning areas of a creative space should not be conceived in a rigid way, but flexible and adaptable to every need. In many cases, not all zones are always present individually, but can overlap with each other depending on the means and the need, as well as for the different technological elements. The following defines the learning zones established in the model of the classroom of the future.

**Interaction:** Equipped with an interactive whiteboard, this area illustrates how technology can be used in a traditional classroom to encourage student interaction and participation. It provides the opportunity to experience ways of teaching and more interactive learning within a traditional environment with the help of specific hardware, software and content.

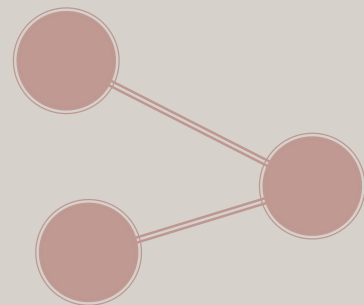
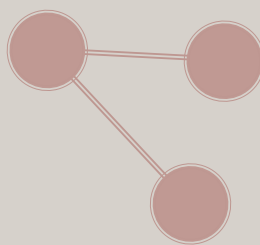

**Intercambio:** Un área particularmente diseñada para desarrollar trabajo en pequeños grupos con la supervisión del profesor. Es ideal para desarrollar trabajos colaborativos y apoyar escenarios de aprendizaje basados en proyectos, fomentando los equipos de trabajo y las habilidades para la dirección de proyectos específicos.

**Exchange:** An area particularly designed to develop work in small groups with teacher supervision. It is ideal for developing collaborative work and supporting project-based learning scenarios, fostering teamwork and project management skills.



**Presentación:** Un área para que el profesorado y el alumnado lleven a cabo las presentaciones de sus trabajos, sus investigaciones, etc. Dispone de una pizarra digital y bancos en gradas, lo que permite a todas las personas participantes verse entre sí, como en un foro, y favorece la participación y la discusión.

**Presentation:** An area for teachers and students to carry out presentations of their work, research, etc. It has a digital whiteboard and benches on bleachers, which allows all participants to see each other, as in a forum, and encourages participation and discussion.



**Desarrolla:** Una zona tranquila donde los alumnos acceden a distintos recursos, realizan investigaciones, trabajan individualmente y aprenden de modo informal. Esta zona se puede usar para desdibujar los límites entre el aprendizaje en casa y en la escuela y, entre otras actividades, se pueden realizar manualidades, ver videos, o experimentar con aplicaciones de software.

**Develop:** A quiet area where students access resources, conduct research, work individually and learn informally. This area can be used to blur the boundaries between learning at home and at school and, among other activities, students can do crafts, watch videos, or experiment with software applications.

**Investigación:** Una zona flexible para el trabajo en grupo, el desarrollo de proyectos y actividades prácticas. Este espacio es idóneo para trabajar con los compañeros, explorar, investigar pequeños objetos usando los ordenadores portátiles y los microscopios, desarrollar habilidades para la resolución de problemas o la programación con robots.

**Research:** A flexible area for group work, project development and hands-on activities. This space is ideal for working with peers, exploring, investigating small objects using laptops and microscopes, developing problem-solving skills or programming with robots.





## Aula del futuro 100m2

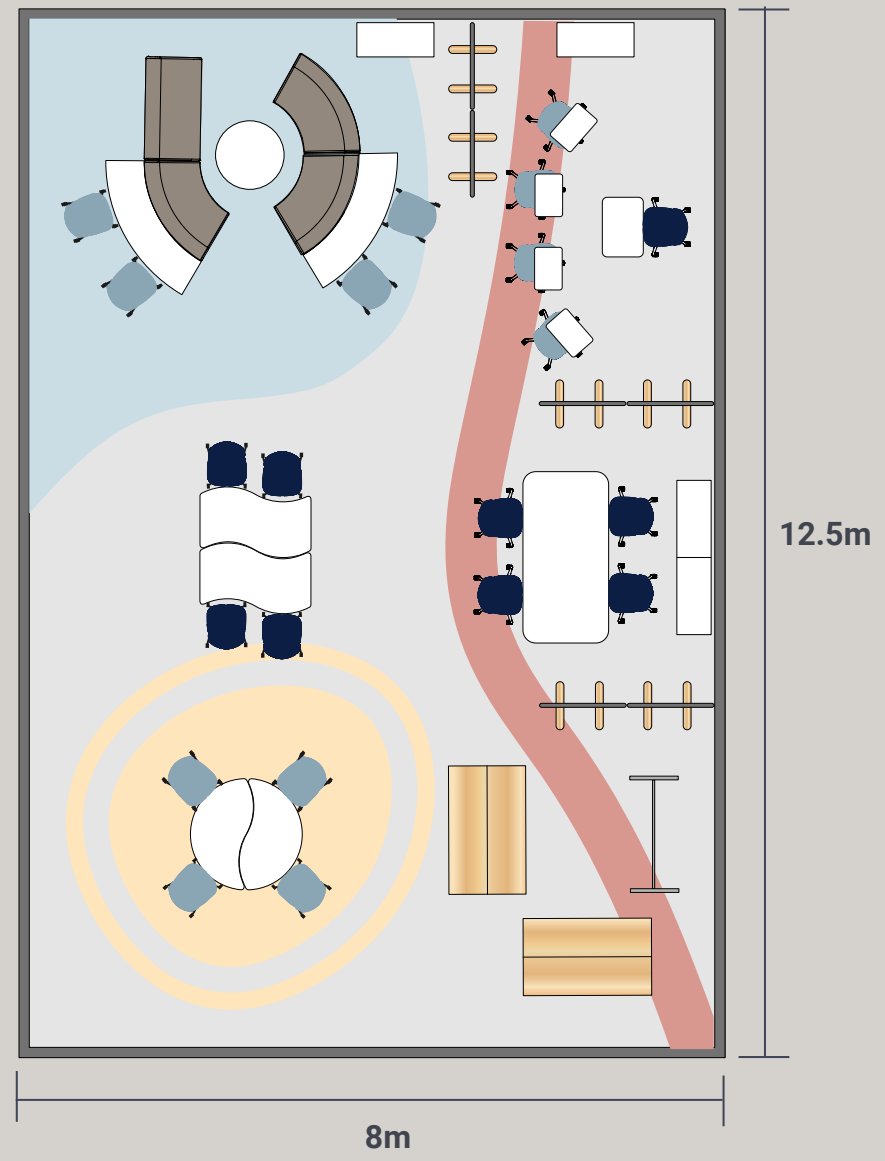

PROVEEDOR OFICIAL  
**aula del futuro**

### Zona Investigación



### Zona Interacción



### Zona Intercambio



### Zona Desarrollo



### Zona Presentación



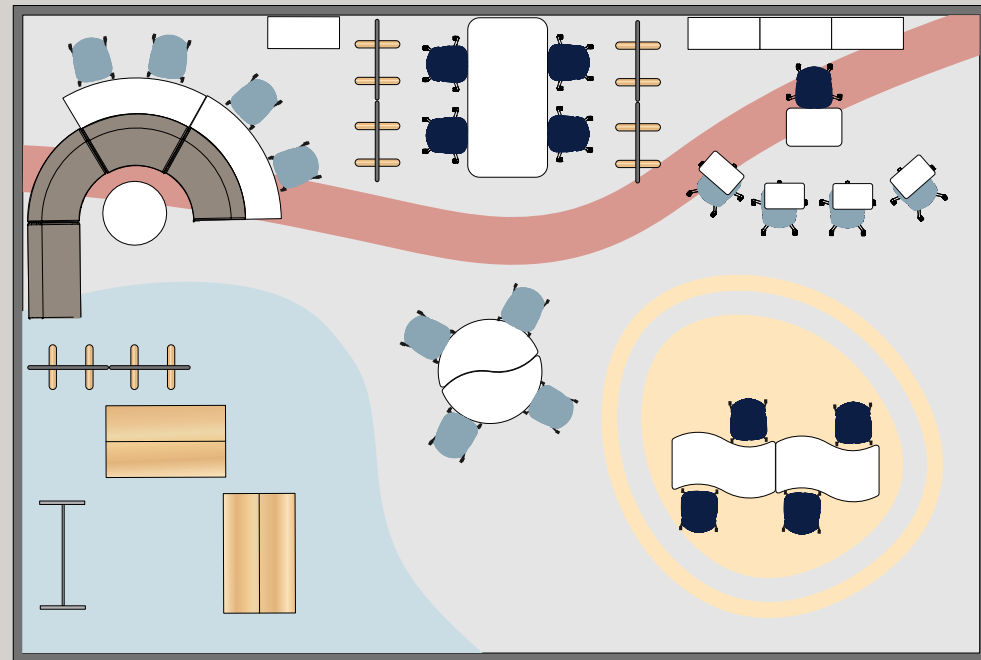
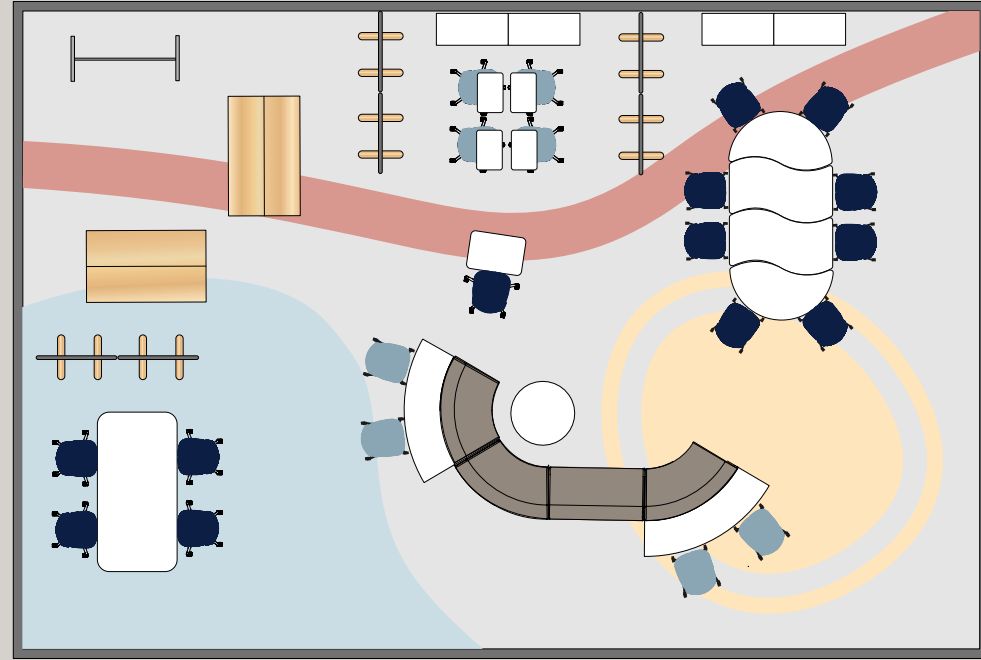



## Aula del futuro 150m2

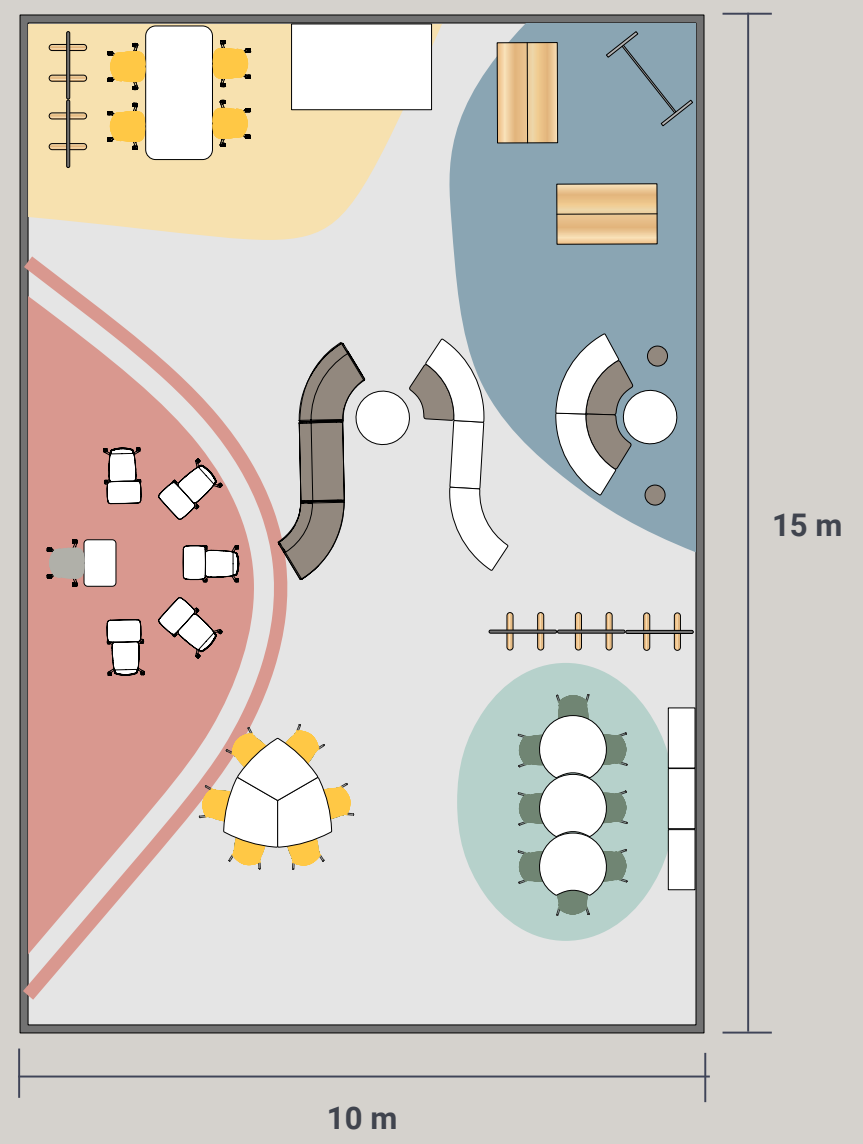

PROVEEDOR OFICIAL  
**aula del futuro**

### Zona Investigación



### Zona Intercambio



### Zona Presentación

### Zona Desarrollo



### Zona Interacción



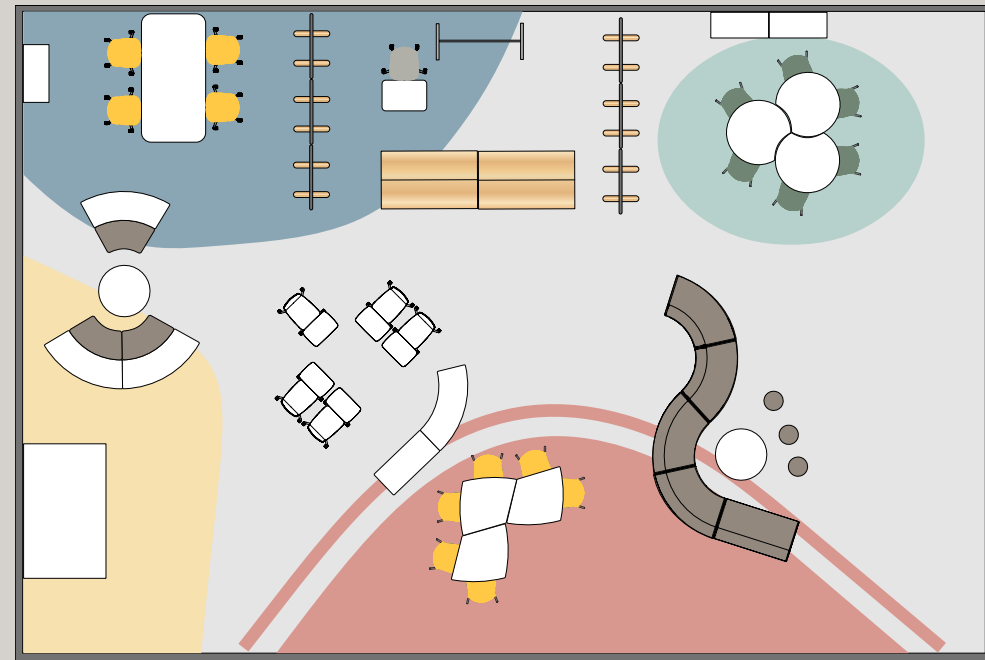
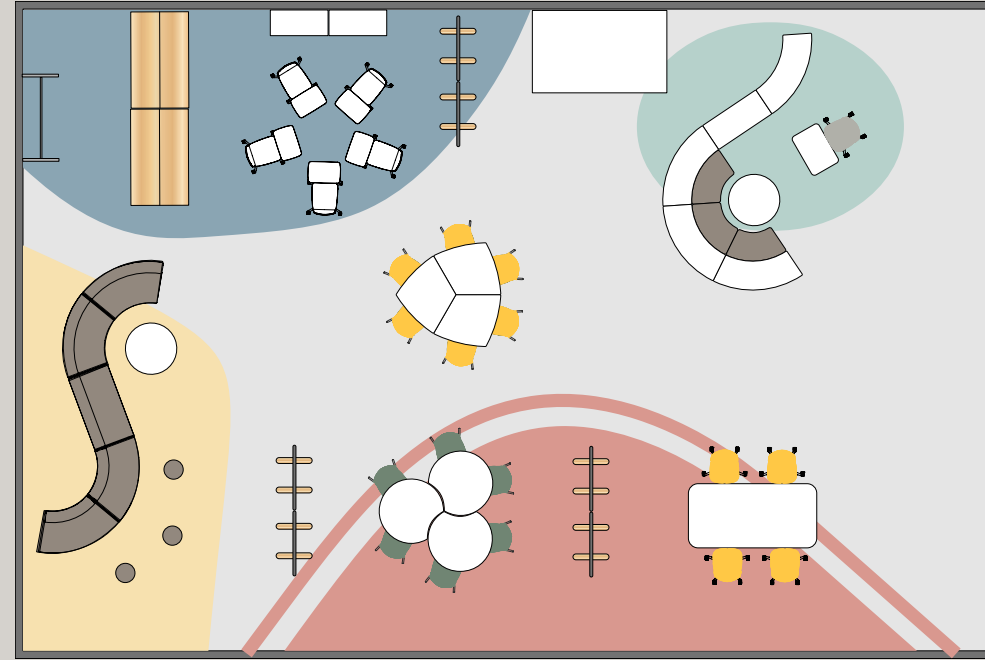

# Aula formación



**Meet Basket**  
SUM190



**Meet Confort**  
SUM100B



**Mesa profesor**  
ASA501



**Meet Skate**  
SUM140



**Pupitre Meet**  
PAP100





**Pupitre Ágil**  
MPM854



**DIDA Active**  
SAC520



**DIDA Basket**  
SAC590



**Mesa Tutor Ágil**  
MPA800



**Taburete DIDA**  
TCA500



## Aula convencional



**Pupitre DIDA**  
MAB500



**DIDA Classic**  
SAC500



**Mesa Profesor**  
MPA500



**DIDA Confort**  
SAC500B



**Armario gavetero**  
ASN306



**Armario con puertas**  
ASN307





**Pupitre DIDA Trapezoidal**  
MAB510



**DIDA Classic**  
SAC500



**Mesa profesor**  
MPA500



**DIDA Confort**  
SAC500B



**Armario gavetero**  
ASN306



**Armario con puertas**  
ASN307

## Aula convencional 45m2

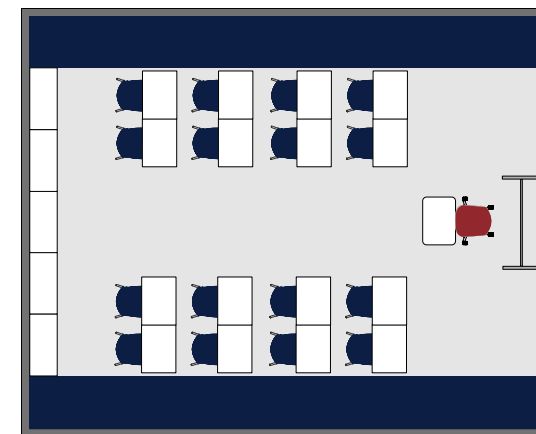

Mesa tutor  
MPA100



Taburete DIDA  
TAC580



Pupitre FG  
MFG63X



Silla DIDA  
SAC500



Armario con puertas  
ASN307



Armario gavetero  
ASN306



Armario con estantes  
ASN301



Pizarra móvil  
PRH100

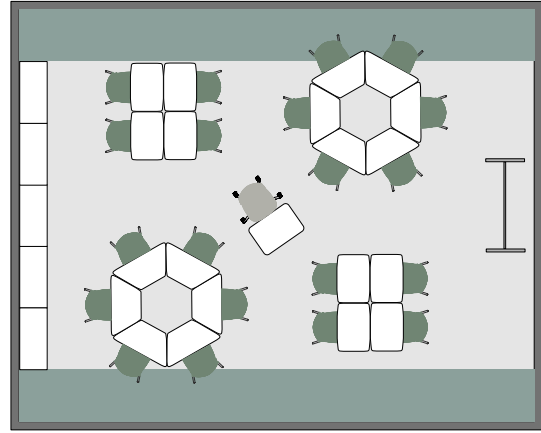

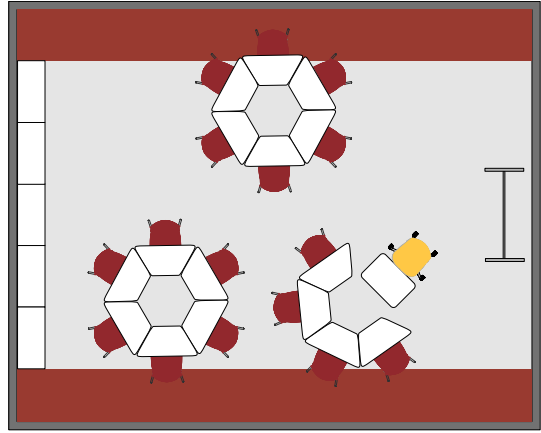

Mesa Tutor  
MPA100



Taburete DIDA  
TAC580



Pupitre Trapezoidal Actiflex  
MAB105



Silla DIDA  
SAC500



Armario con puertas  
ASN307



Armario Gavetero  
ASN306



Armario Recto  
AAC105



Pizarra móvil  
PRH100





**Mesa Loop**  
Modelo 153



**DIDA Move**  
SAC580



**Taquilla**  
\*Sobre proyecto



**Taburete DIDA**  
TAC500



**Mesa alta**  
MLA2008



**Armario gavetero**  
ASN306

# Aula primaria

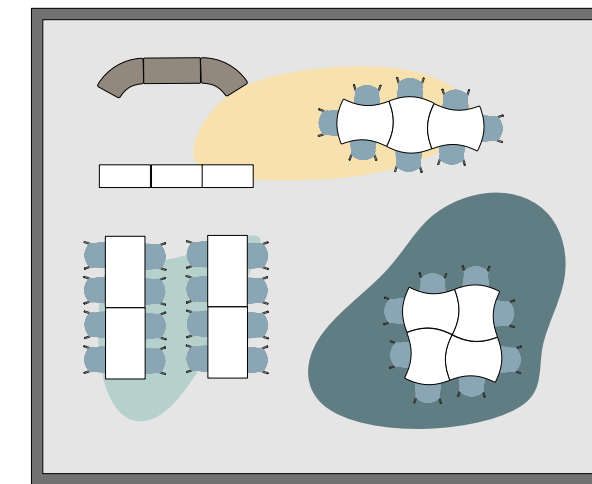

**Armario gavetero**  
ASM06



**Armario con estantes**  
ASM201



**Softseating curvo bajo**  
BAC115



**Softseating recto bajo**  
BAC105



**Silla DIDA**  
SAC500



**Mesa loop**  
MAC153



**Mesa ágil**  
MPM854





# Infantil

48



Mesa Bend  
Modelo 155



Estantería baja  
ASB101



Armario gavetero bajo  
ASB104



Softseating bajo curvo  
BAC115



Soft seating bajo recto  
BAC105



Silla Postura  
SAP37X





**Mesa Yang**  
Modelo 162



**Mesa Ola**  
Modelo 161



**Armario bajo**  
ASB104



**Softseating bajo curvo**  
BAC115



**Soft seating bajo recto**  
BAC105



**Soft seating circular**  
BAC040



**Taburete Chambo**  
TAB568



**Silla Postura**  
SAP37X

# Biblioteca



**Silla DIDA**  
SAC500



**Mesa Diamond**  
MAC152



**Mesa Mopac**  
MAC158



**Armario Gavetero**  
AS2306



**Mesa Circular**  
MLO0006



**Taburete DIDA**  
TAC580



**Armario Alto**  
ASA501



**Grada**  
GAC100



**Serp Recto**  
SRE200



**Serp Curvo C**  
SCC200



**Serp Curvo A**  
SCA200



**Armario Curvo**  
AAC110



**Armario Recto**  
AAC105



**Softseating curvo**  
BAC110



**Soft seating circular**  
BAC040



**Mesa alta**  
MCA200





**Cabina Acústica Doble**  
CAD200



**Meet Classic**  
SUM100



**Mesa rectangular**  
MLO2008



**Taburete Meet**  
TUM140



**Mesa Alta**  
MLA2008



**Armario Recto**  
ASN301



**Cabina Acústica Individual**  
CAS100



**DIDA Wood**  
SAC530



**Mesa rectangular**  
MLO2008



**SERP recto**  
SRE200



**SERP curvo cerrado**  
SCE200



**Mesa Circular**  
MLO006



# Comedor



Mesa Circular  
ML00012



Silla Hatton  
SAP378

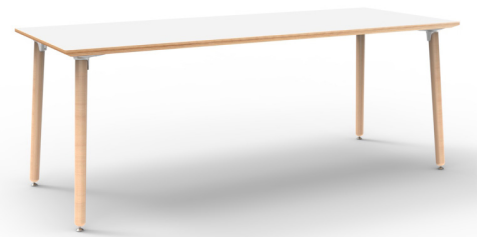

Mesa rectangular  
ML02008



SERP recto  
SRE200



Mesa cuadrada  
ML00808



DIDA Wood  
SAC530



Silla Postura  
SAP375



Taburete carcasa Postura  
TCA375



Mesa Ágil  
MPM86



Mesa alta rectangular  
MLA2008





# 03

FEDERICO GINER  
desde 1910

P	T	B	A	B	O	P	V	L	C	O	E	L	O
C	Y	O	B	A	Ñ	C	K	W	B	A	Q	E	A
Q	C	Ñ	A	Ñ	W	Q	C	D	R	K	<b>P</b>	Z	K
R	N	R	S	B	P	K	C	I	R	S	<b>R</b>	K	Y
Y	X	A	S	A	B	Y	M	O	P	R	<b>O</b>	O	R
C	U	V	P	X	W	C	T	P	Y	A	<b>D</b>	E	A
L	Ñ	Q	A	Z	B	L	Ñ	V	U	I	<b>U</b>	M	I
C	P	P	C	T	L	C	L	N	Z	Ñ	<b>C</b>	P	Ñ
C	Q	H	I	A	B	C	A	G	X	J	<b>T</b>	T	J
C	Y	G	O	B	V	C	C	H	L	K	<b>O</b>	L	K
C	L	I	S	R	Q	C	O	K	R	L	<b>S</b>	S	L
M	Y	K	R	E	Z	M	P	B	W	M	V	P	M





# Sillas



**DIDA Classic**  
SAC500

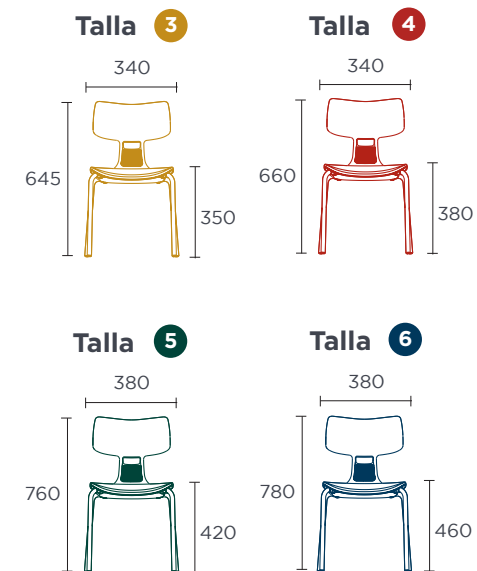

Ver colección

**DIDA Confort**  
Ref. SAC500B

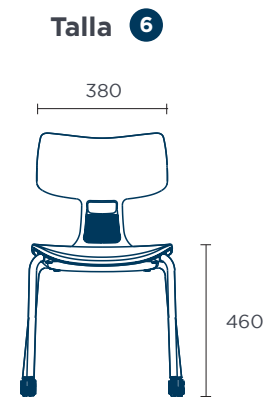

### DIDA Pad 360

Ref. SAC560



Talla **6**

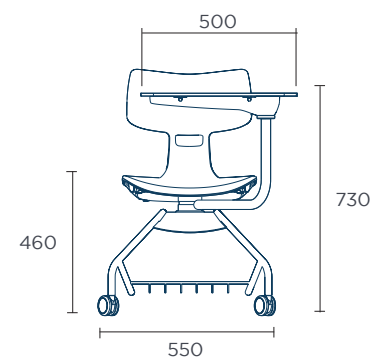

#### Carcasa



Ash Grey



Olive Green



Powder Blue



Nordic



Valencia Yellow



Cayenne

#### Base



Negro



Aluminio

### DIDA Pad

Ref. SAC570



Talla **5** **6**

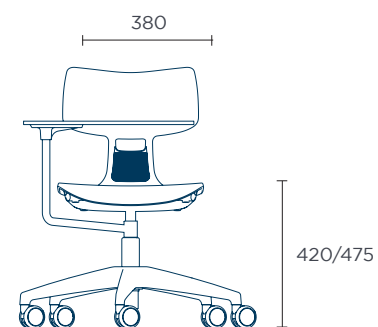

#### Carcasa



Ash Grey



Olive Green



Powder Blue



Nordic



Valencia Yellow



Cayenne

#### Base



Negro

\*15% de material reciclado



**DIDA Wood**  
Ref. SAC530

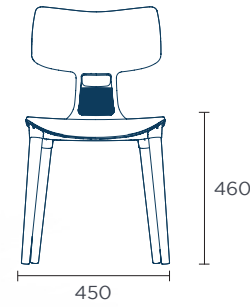

**Patas**



Haya

**Carcasa**



Ash Grey



Olive Green



Powder Blue



Nordic



Valencia Yellow



Cayenne

**DIDA Active**  
Ref. SAC520



**Talla 6**

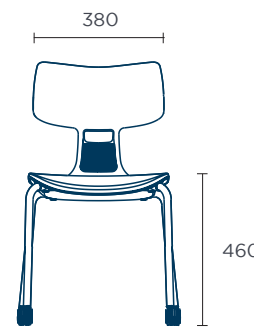

**Carcasa**



Ash Grey



Olive Green



Powder Blue



Nordic



Valencia Yellow



Cayenne

**Patas**



Aluminio



Blanco

\*15% de material reciclado

**DIDA Basket**  
Ref. SAC590



**Talla 6**

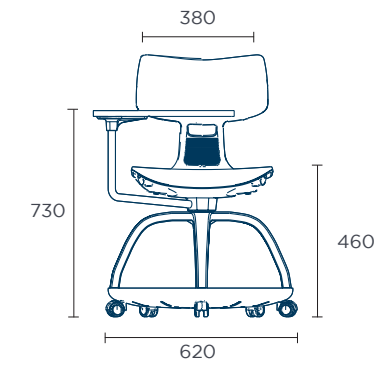

**Carcasa**



Ash Grey



Olive Green



Powder Blue



Nordic



Valencia Yellow



Cayenne

**Base**



Negro

**DIDA Move**  
Ref. SAC580



**Talla 5 6**

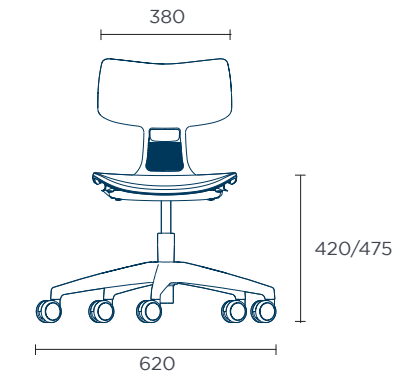

**Carcasa**



Ash Grey



Olive Green



Powder Blue



Nordic



Valencia Yellow



Cayenne

**Base**



Negro

\*15% de material reciclado



**Taburete DIDA**  
Ref. TAC580

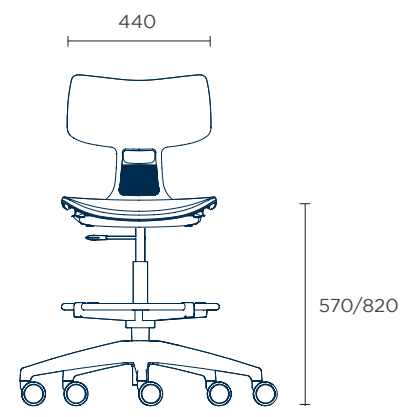

- Carcasa**
- Ash Grey
  - Olive Green
  - Powder Blue
  - Nordic
  - Valencia Yellow
  - Cayenne
- Base**
- Negro

**Taburete DIDA Confort**  
Ref. TAC580B

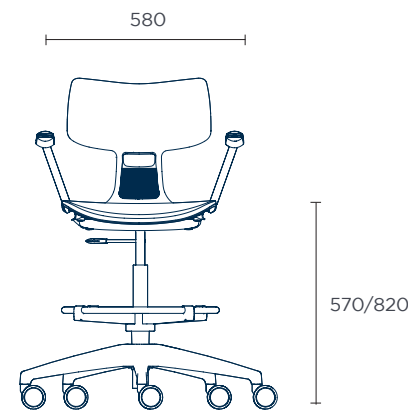

- Carcasa**
- Ash Grey
  - Olive Green
  - Powder Blue
  - Nordic
  - Valencia Yellow
  - Cayenne
- Base**
- Negro

**Meet Classic**  
Ref. SUM100

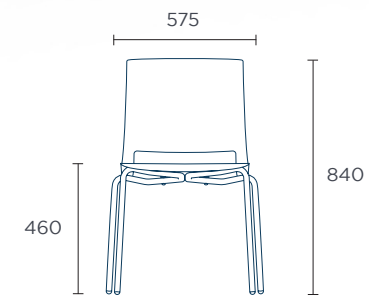

**Meet Classic Confort**  
Ref. SUM100B

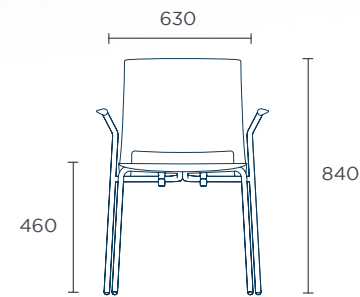

**Meet Skate**  
Ref. SUM140

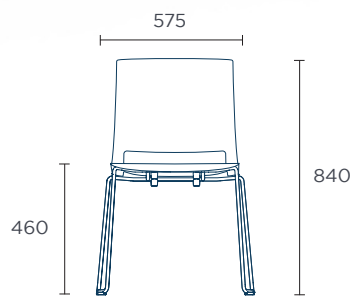

**Taburete Meet**  
Ref. TUM140

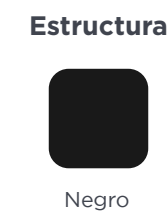
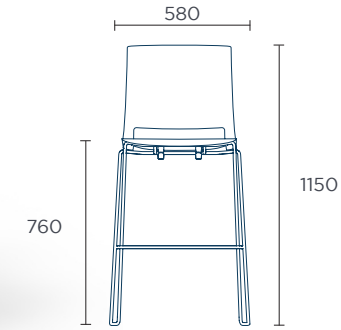

Ver colección



**Meet Cantilever**  
Ref. SUM160

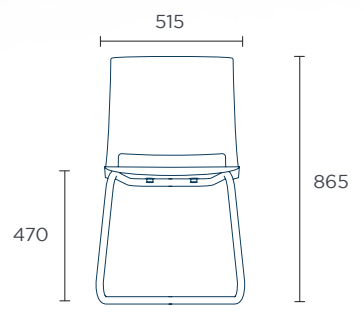

- Carcasa**
- Gris Cemento
  - Verde Caña
  - Anthracite

**Meet Move**  
Ref. SUM180

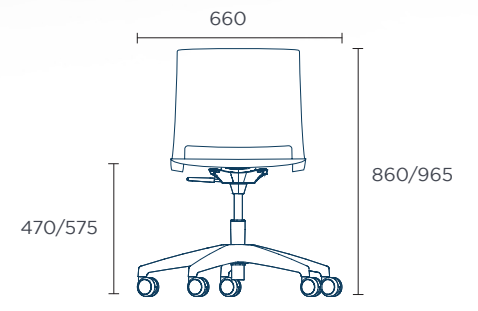

- Estructura**
- Negro

**Meet Basket**  
Ref. SUM190

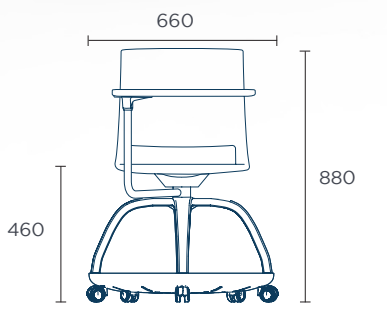

- Carcasa**
- Lisa
  - Perforada

## Taburete Chambo

Ref. TAC568

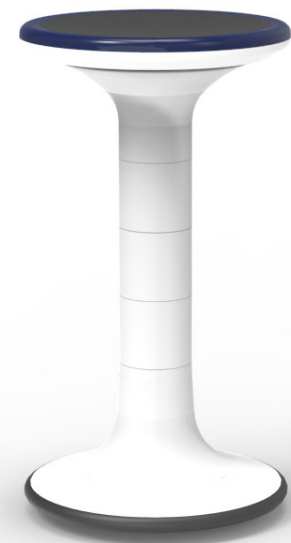

Cuerpo



Blanco

Asiento



Negro

Talla 2 Talla 4 Talla 6 Talla 7

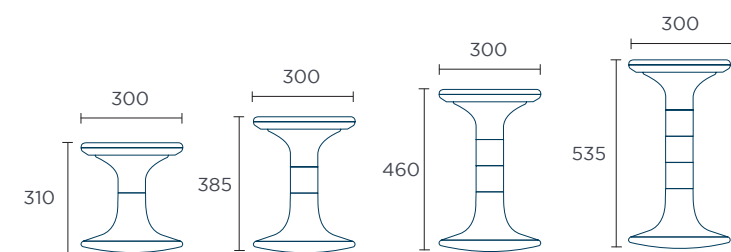

76



## Silla Postura +

Ref. SAP37x

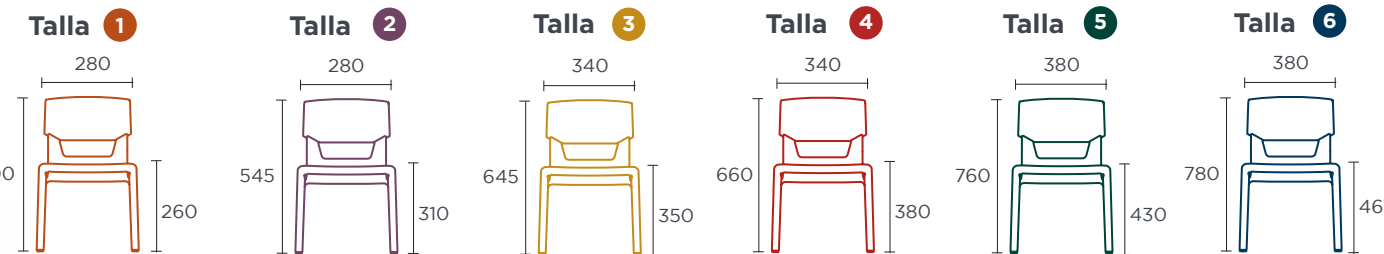

Polipropileno



Rose Bloom



Ash Grey



Powder Blue



Olive Green



Hazy Jade



Light Sand

77

## Silla Hatton

Ref. SAP378



Talla 6

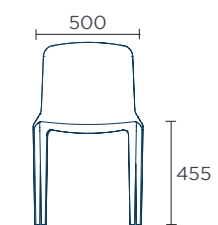

Polipropileno



Rose Bloom



Iron Grey



Ash Grey



Powder Blue



Olive Green



Purple Haze



Flannel

### Postura Wood

Ref. SCA375



### Taburete Carcasa Wood

Ref. TCA375



### Taburete Asiento Wood

Ref. TAS375



### Taburete Carcasa Postura

Ref. TCA564

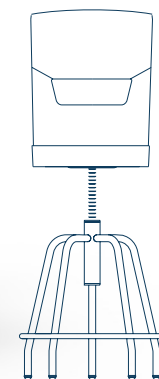

#### Polipropileno



Rose Bloom



Ash Grey



Powder Blue



Olive Green



Hazy Jade



Light Sand

#### Patas



Aluminio

#### Base



Negro

### Taburete Carcasa Postura Move

Ref. TCA566

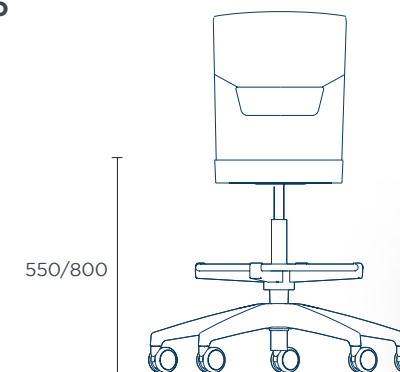

### Taburete Asiento Postura Move

Ref. TAS566

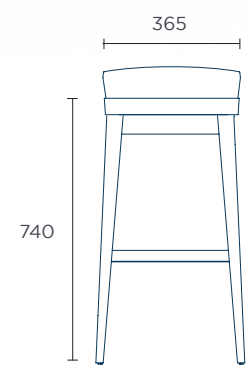
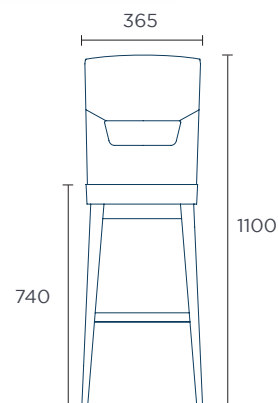
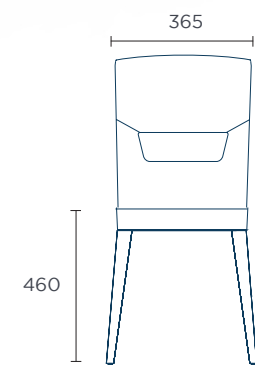
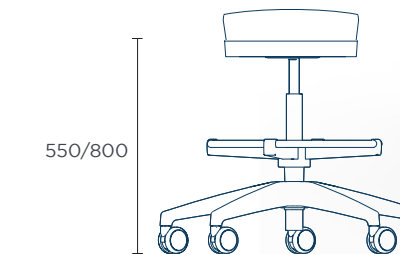

#### Polipropileno



Rose Bloom



Ash Grey



Powder Blue



Olive Green



Hazy Jade



Light Sand



**Pad Chair**  
Ref. SAC360

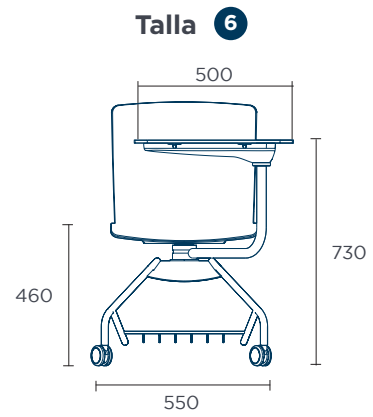

**Carcasa**

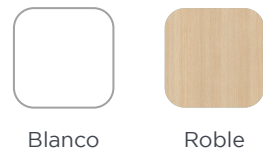

**Base**

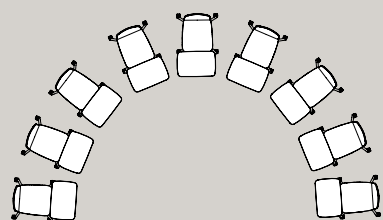
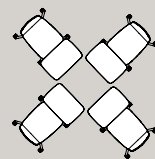
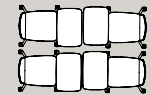
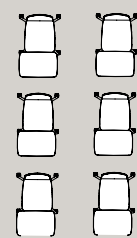
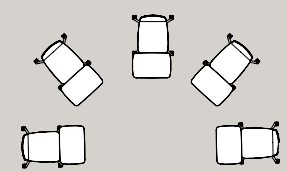
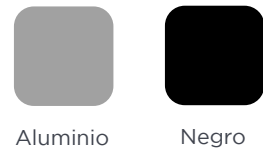

Ver colección

**Master Pro**  
Ref. SOF500



**Master Pro Confort**  
Ref. SOF550



**Master Pro Active**  
Ref. SOF504



**Master Pro Move**  
Ref. SOF400

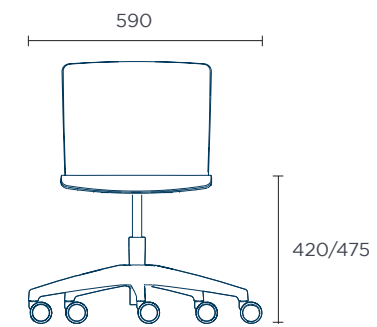

**Base**



Negro

**Carcasa**



Blanco



Roble

**Master Pro Move Confort**  
Ref. SOF450

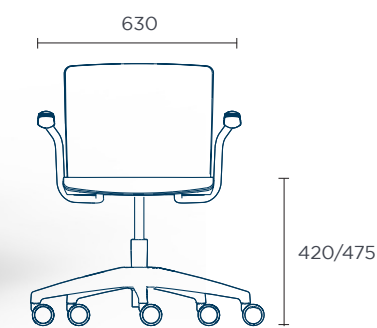

Talla 6

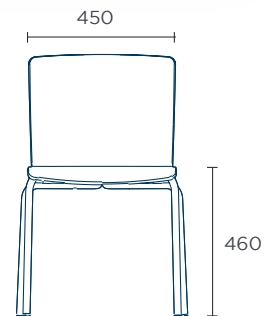

Talla 6

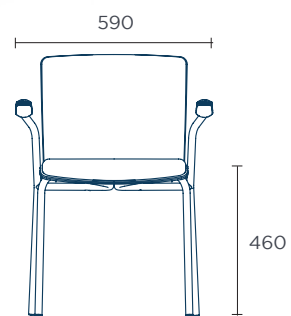

Talla 6

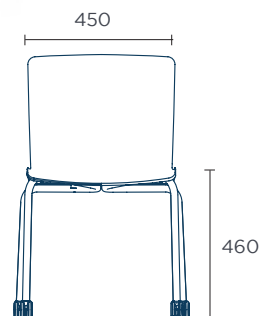

**Patas**



Aluminio

**Carcasa**



Blanco



Roble



**Silla Oficina**  
Ref. SOF200

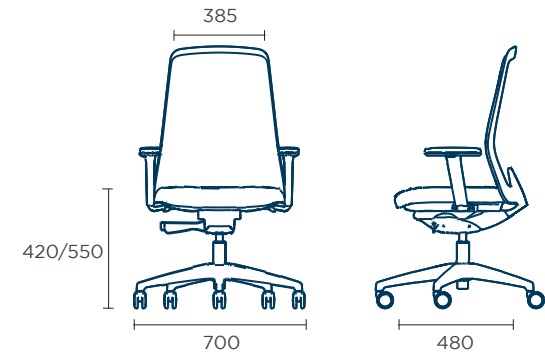

**Tapizado**



Negro

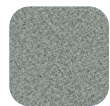

Gris

**Carcasa**



Negro



Blanco

**Base**



Negro



# Mesas



## MESAS ACTIFLEX®

Mesas modulares diseñadas para las nuevas metodologías son altamente versátiles y se adaptan a las necesidades cambiantes de cualquier entorno de trabajo. Con la capacidad de regular la altura, proporcionan una ergonomía óptima para diferentes usuarios. Ya sea fija o móvil, su sistema de peana robusta garantiza estabilidad y durabilidad. Estas mesas son el complemento perfecto para potenciar la colaboración y la creatividad en cualquier espacio.

Modular tables designed for new methodologies are highly versatile and adapt to the changing needs of any work environment. With the ability to adjust the height, they provide optimal ergonomics for different users. Whether fixed or mobile, their sturdy pedestal system ensures stability and durability. These tables are the perfect complement to enhance collaboration and creativity in any space..



Ver colección



Sistema de sujeción patentado

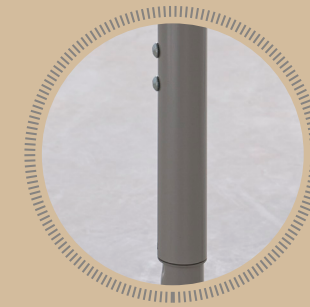

Tallas de 3 a 6 pata regulable  
Tallas 1 y 2 pata fija



Opción pata fija con nivelador



Opción pata móvil

## Modelos



Loop



Diamond



Yang



Ola



Mopac



Half



Moon



Kite



Bend



Link

**Mesa Loop**  
Modelo 153

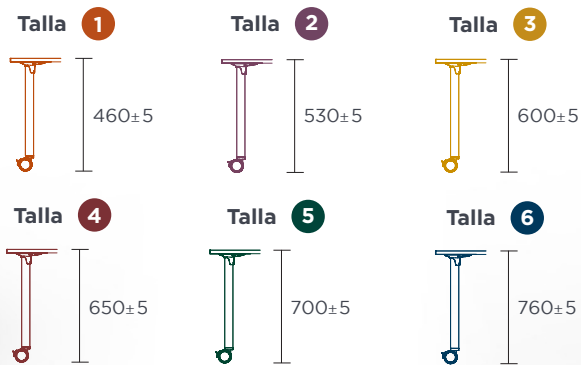

**Superficie**

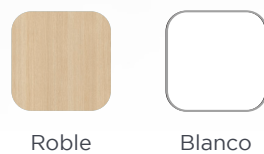

**Tablero**

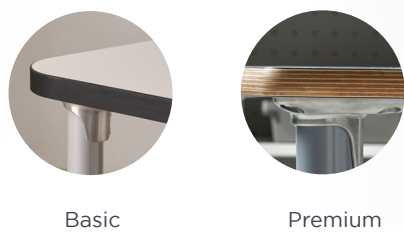

**Mesa Diamond**  
Modelo 152



**Patas**

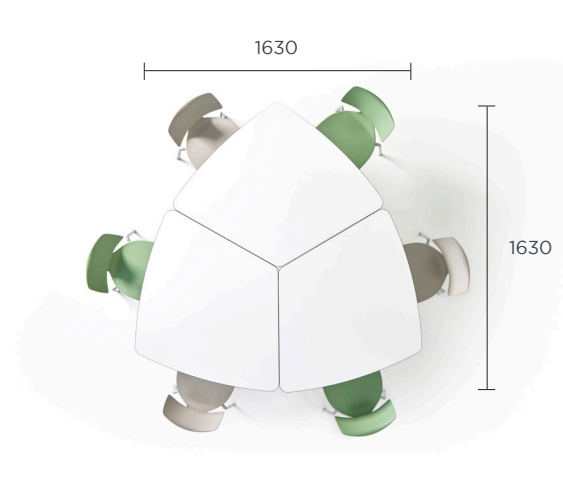
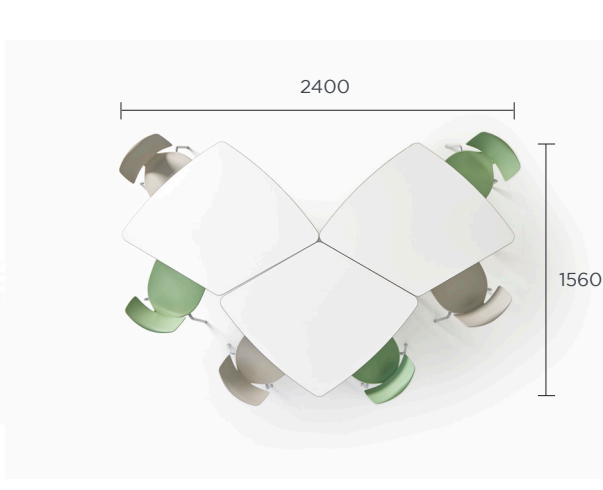
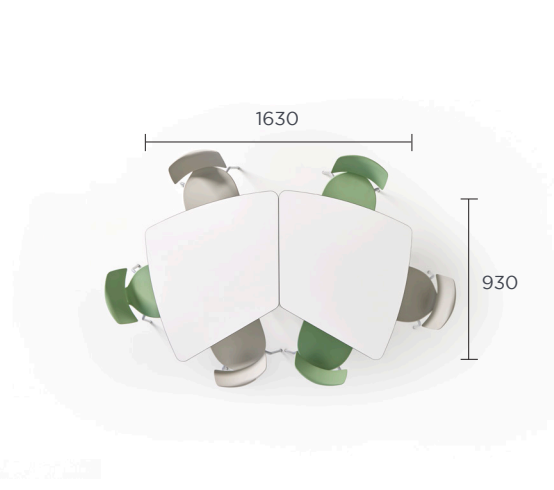
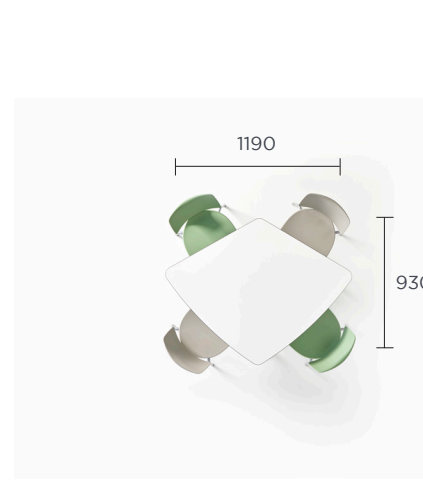
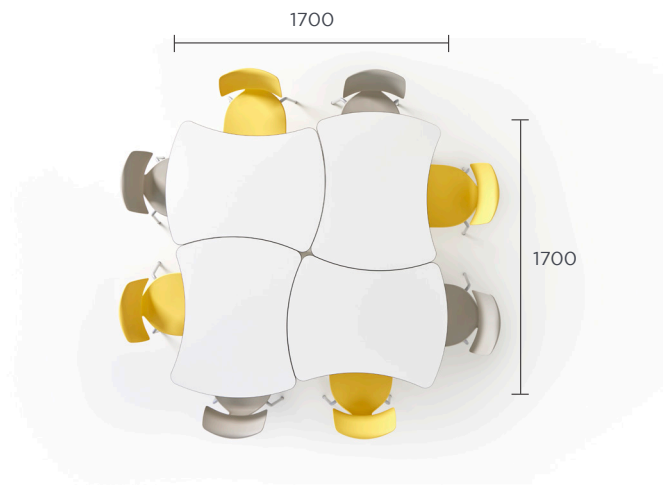
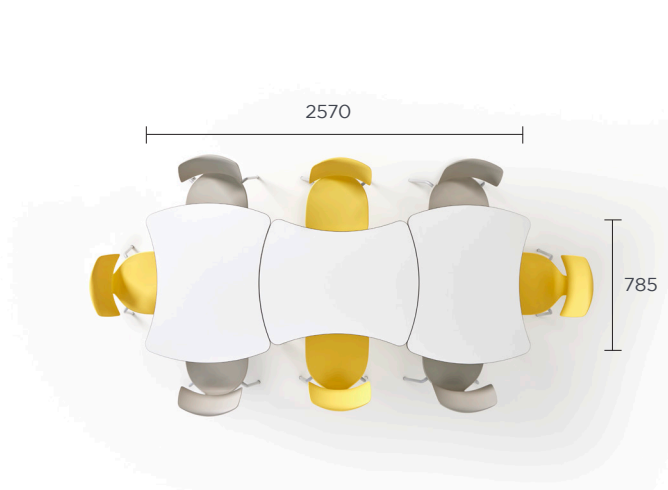
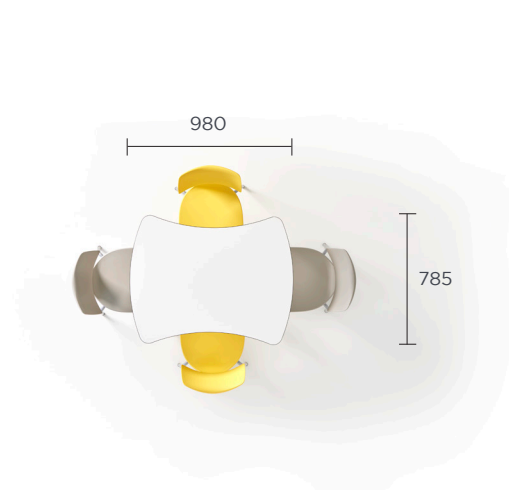
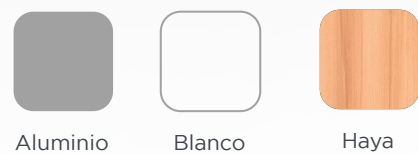

**Mesa Yang**  
Modelo 162

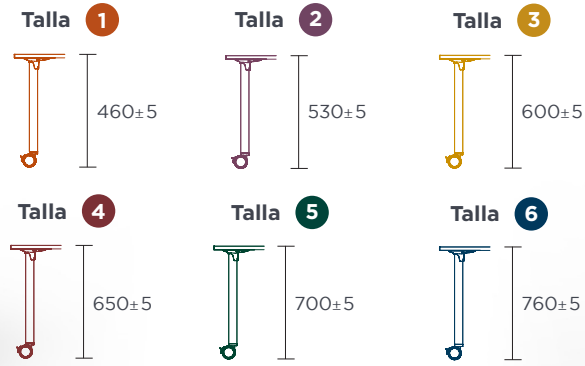

**Mesa Ola**  
Modelo 161



90

**Superficie**

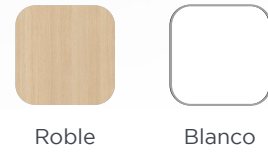

Roble Blanco

**Tablero**



Basic Premium

**Patas**



Aluminio Blanco Haya

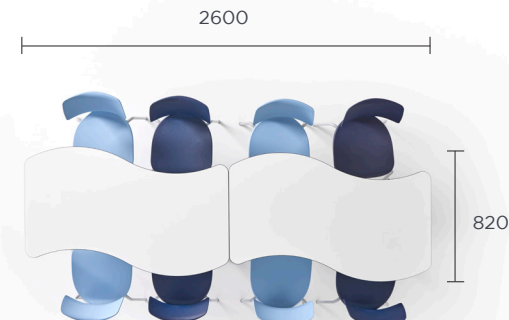
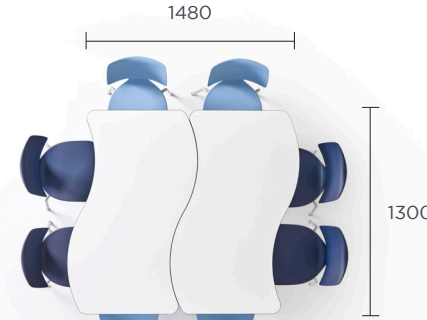
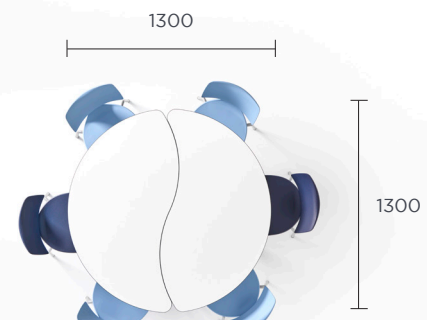
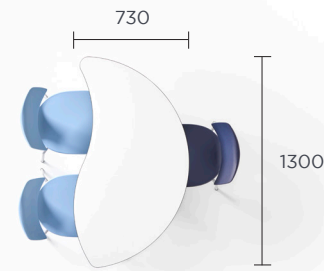

91



**Mesa Mopac**  
Modelo 158



**Mesa Half**  
Modelo 156



**Mesa Moon**  
Modelo 154

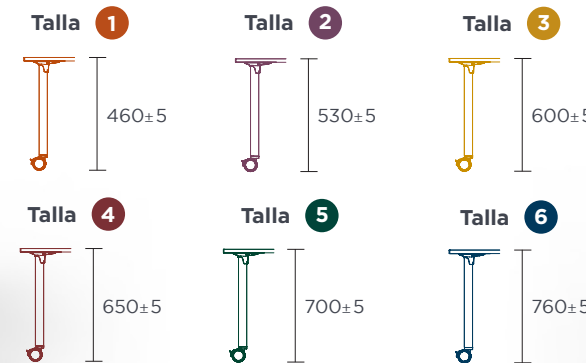

**Mesa Kite**  
Modelo 151



**Superficie**

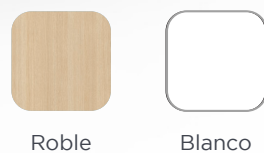

**Tablero**

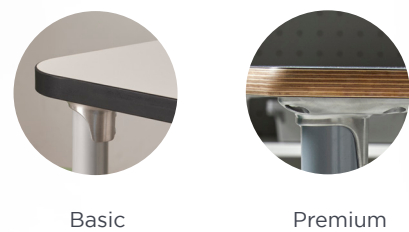

**Patas**

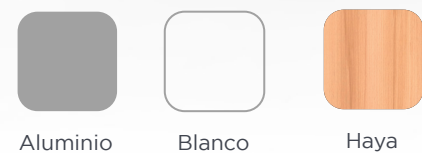

**Superficie**

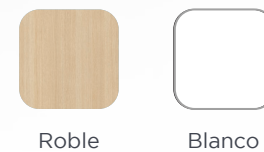

**Tablero**

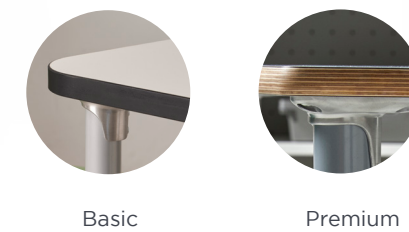

**Patas**

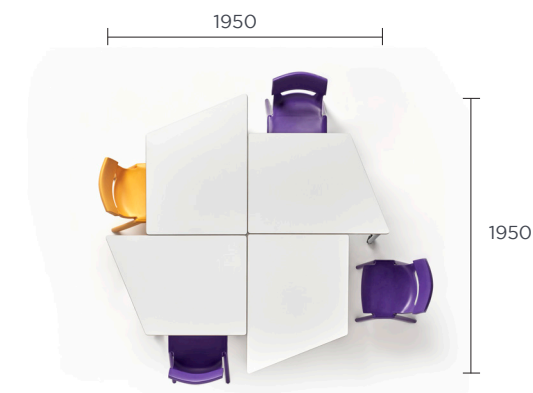
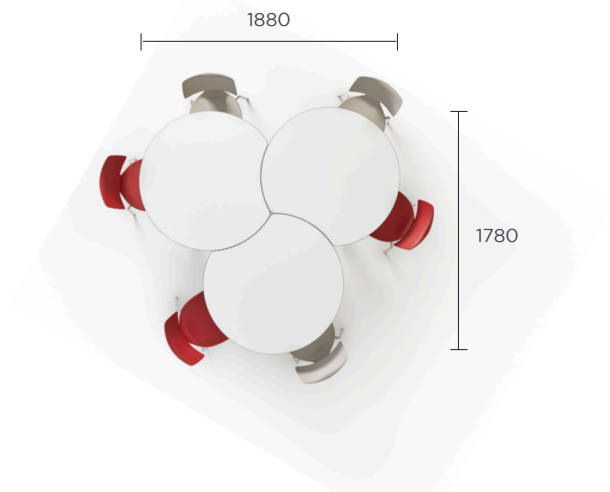
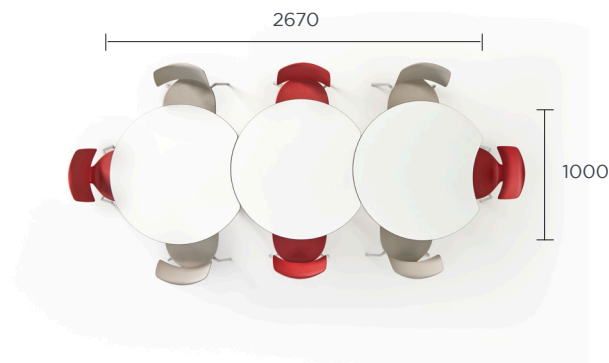
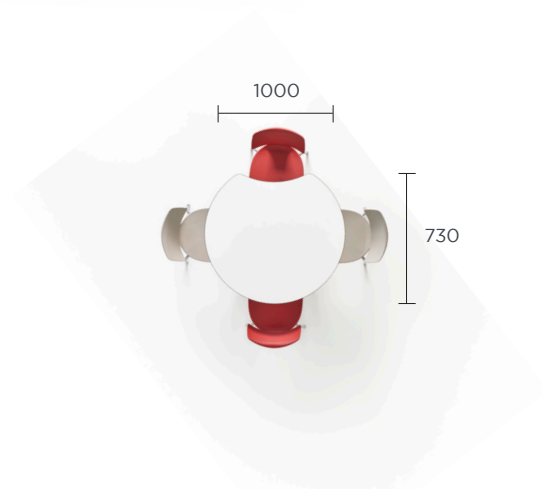
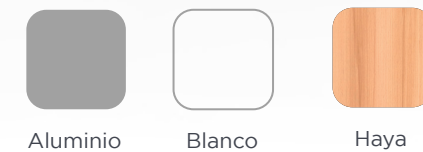

**Mesa Bend**  
Modelo 155

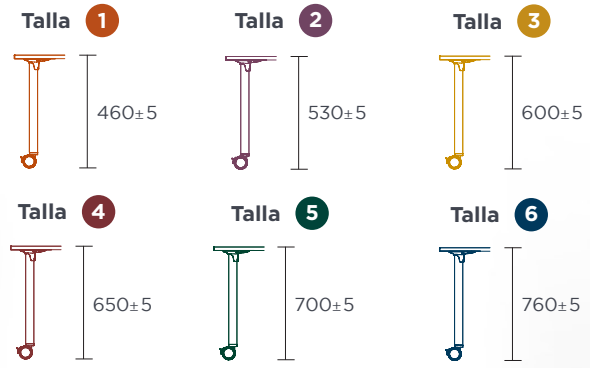

**Mesa Link**  
Modelo 150



94

**Superficie**

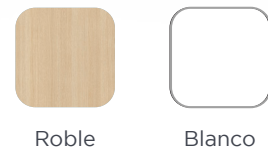

**Tablero**

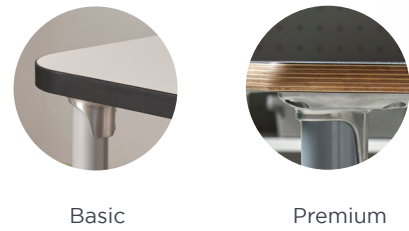

**Patas**

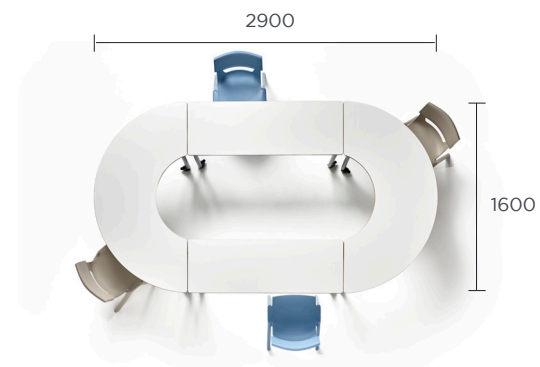
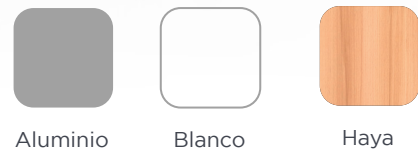





**Mesa Tutor**  
Ref. MPA100



**Superficie**

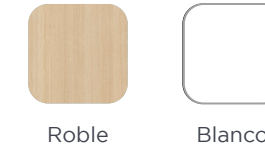

**Patas**



**Tablero**



Basic

Premium

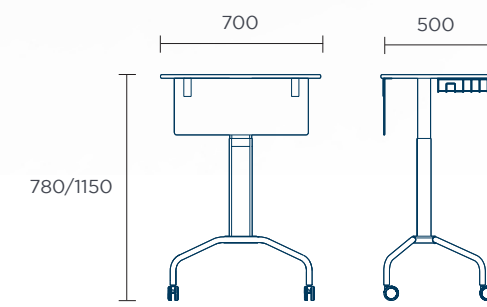

**Mesa Tutor Ágil**  
Ref. MPA800

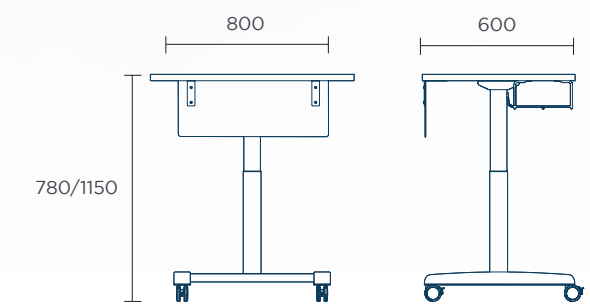



### Mesa Profesor

Ref. MPA500

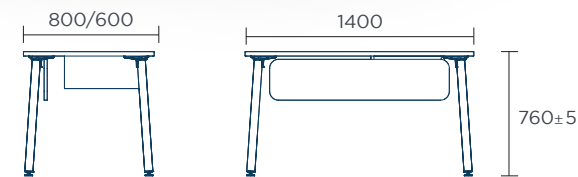

#### Superficie



Roble



Blanco



Aluminio



Blanco

#### Patas



Basic



Premium

#### Tablero

### Mesa Modular

Ref. MM076x



#### Superficie



Roble



Blanco



Aluminio



Blanco

#### Patas

#### Tablero



Basic



Premium

#### Talla 1

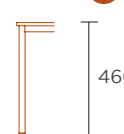

#### Talla 2

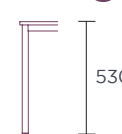

#### Talla 3

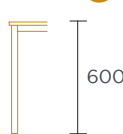

#### Talla 4

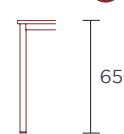

#### Talla 5



#### Talla 6

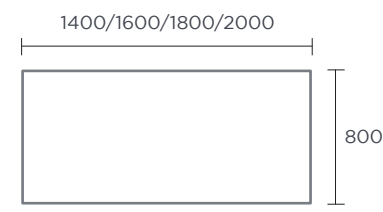
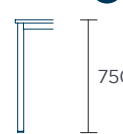

#### Talla 1

#### Talla 2

#### Estudio de capacidades

#### Talla 3

#### Talla 4

#### Talla 5

#### Talla 6

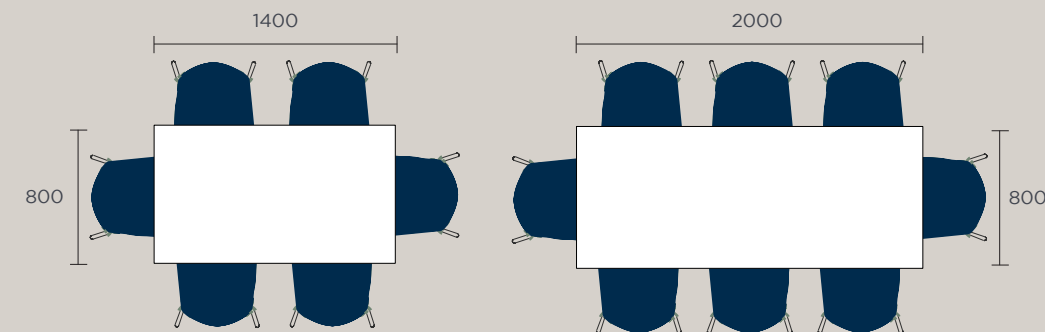
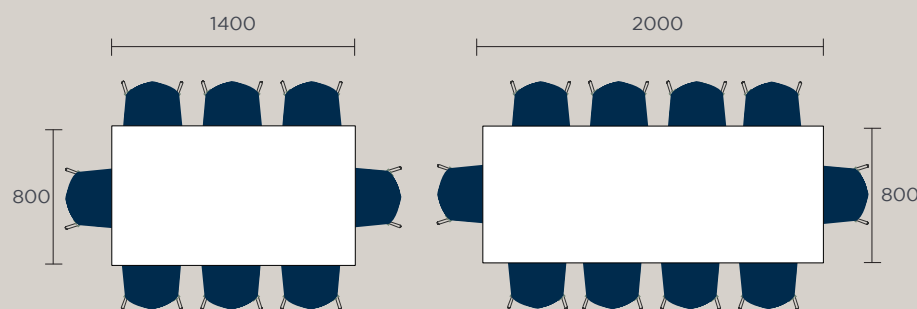

**Mesa Ágil**  
Ref. MPM86x



100



**Tallas**

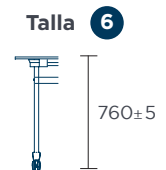
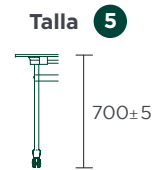
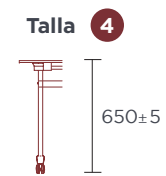
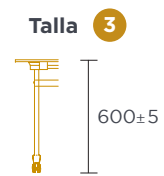

**Superficie**



Roble



Blanco



Aluminio



Blanco

**Patas**

**Tablero**



Basic



Premium

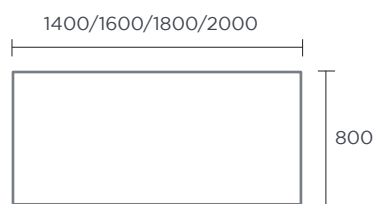

**Estudio de capacidades**

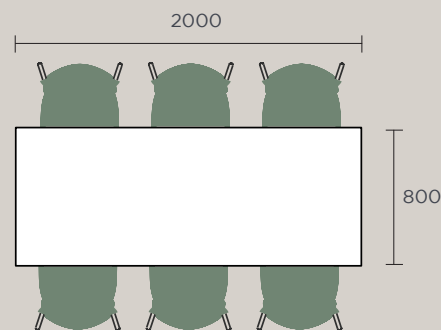
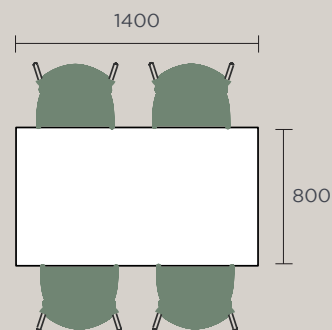



## Mesas Living

Actiflex Living es una colección de mesas versátiles que se adaptan a diversos espacios. Concebidas para integrarse armoniosamente en su entorno, estas mesas representan una combinación equilibrada entre funcionalidad y estética refinada, añadiendo un toque de distinción discreta a cualquier ambiente donde se ubiquen.

Actiflex Living is a collection of versatile tables that adapt to a variety of spaces. Designed to blend harmoniously into their surroundings, these tables represent a balanced combination of functionality and refined aesthetics, adding a touch of discreet distinction to any environment where they are placed.



## Modelos



Mesa cuadrada



Mesa circular



Mesa rectangular



Mesa alta

**Mesa Living Cuadrada**  
Ref. MLO0808



**Superficie**

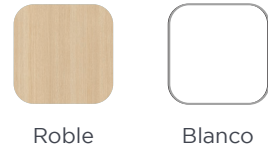

**Patas**



104

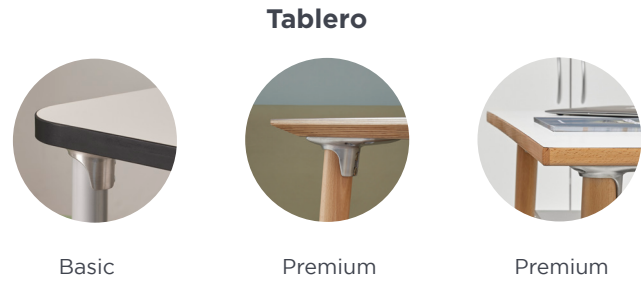
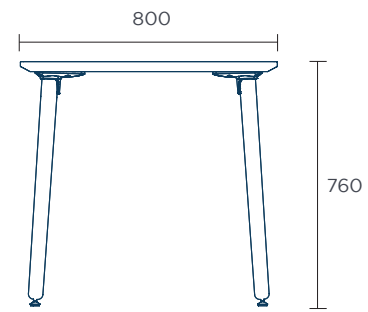

**Mesa Living Circular**  
Ref. MLO0012

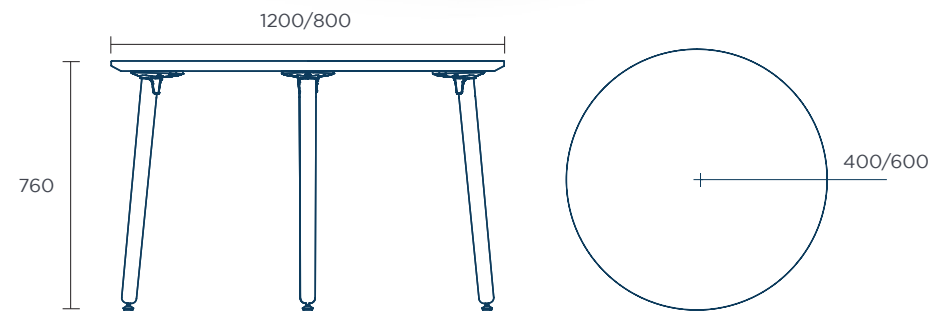

**Tablero**

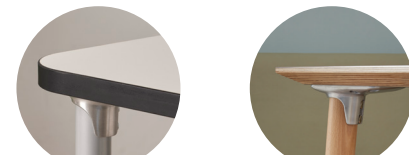

**Mesa Living Alta**  
Ref. MLA2008



**Superficie**

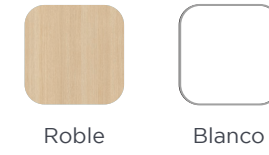

**Patas**

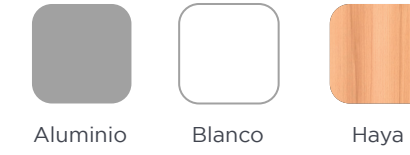

**Tablero**



Basic



Premium



Premium

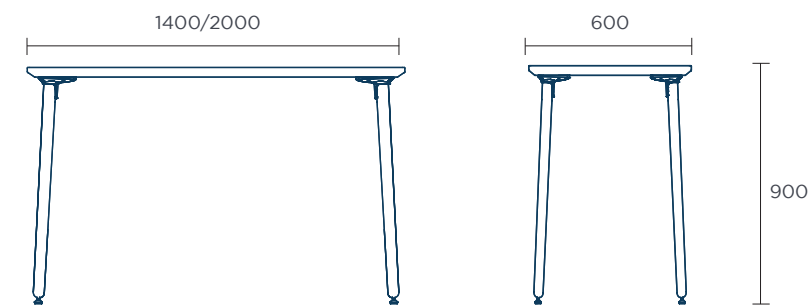
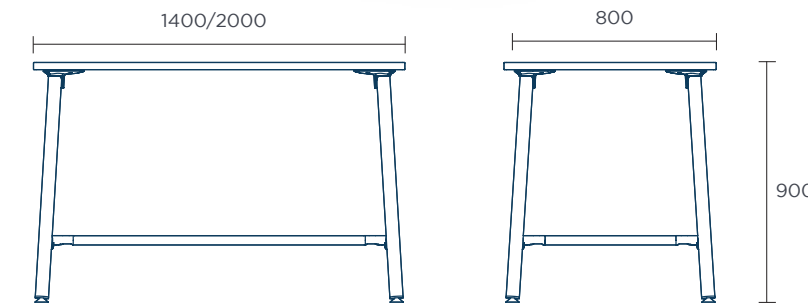

**Mesa Living Rectangular**  
Ref. MLO2008

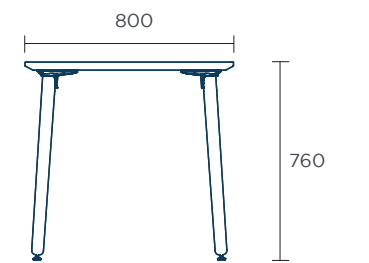
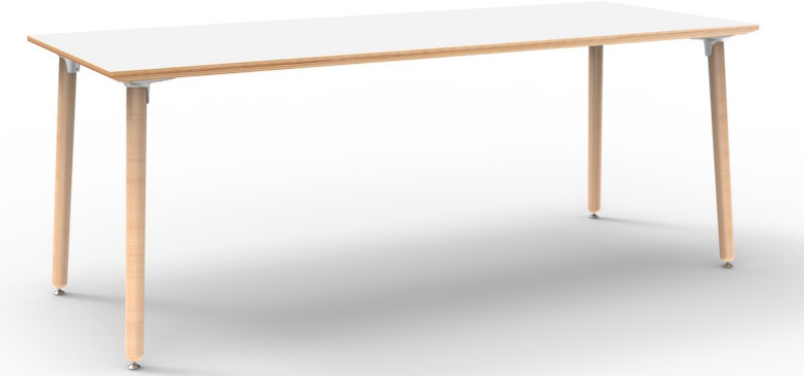

105

# Pupitres



## Pupitre DIDA rectangular

Ref. MAB505



### Superficie



Roble



Blanco

### Patas



Aluminio



Blanco

### Tablero



Basic



Premium

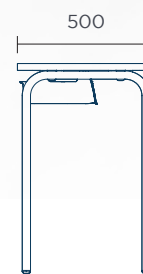

500

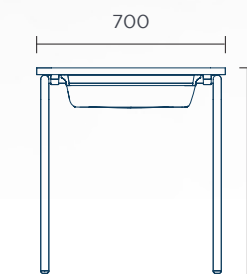

700

765



## Pupitre DIDA trapezoidal

Ref. MAB510

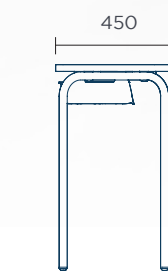

450

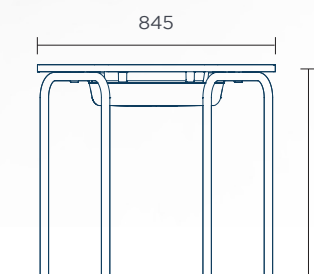

845

765

### FG Box



Powder Blue



Nordic



Cayenne



Ash Grey



Olive Green



Valencia Yellow



Opción Rejilla

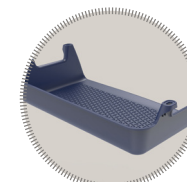

Opción FG Box

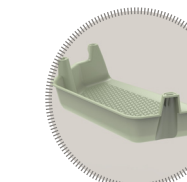

Opción FG Box

### Pupitre Meet Ref. MAB210



**Superficie**

 Negro

 Blanco

**Estructura**

 Negro

**Tablero**

 Basic





### Pupitre rectangular Actiflex Ref. MAB210

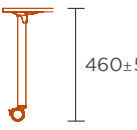

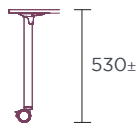
**Talla 1**  
 460±5

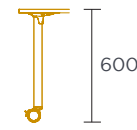
**Talla 2**  
 530±5

**Talla 3**  
 600±5

**Talla 4**  
 650±5

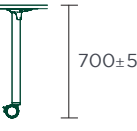
**Talla 5**  
 700±5

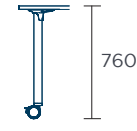
**Talla 6**  
 760±5

#### Tablero



Basic



Premium

#### Superficie



Roble



Blanco

#### Patas



Aluminio



Blanco



Haya



Sistema de sujeción patentado

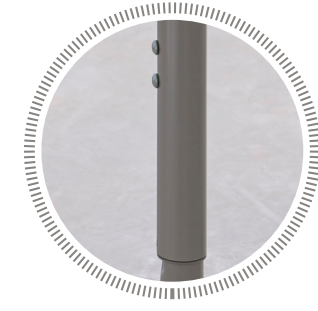

Tallas de 3 a 6 pata regulable  
Tallas 1 y 2 pata fija

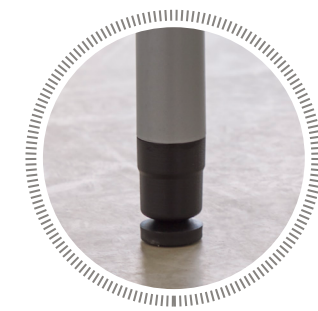

Opción pata fija con nivelador



Opción pata móvil

### Pupitre trapezoidal Actiflex Ref. MAB205



**Pupitre rectangular**  
Ref. MAC110



**Tablero**

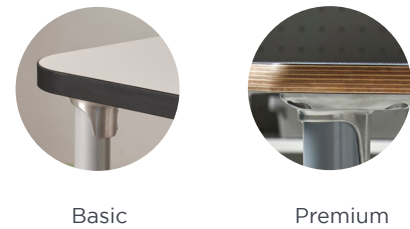

**Pupitre trapezoidal**  
Ref. MAC105

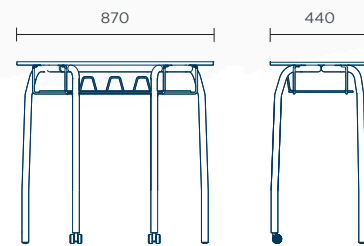

Rejilla opcional

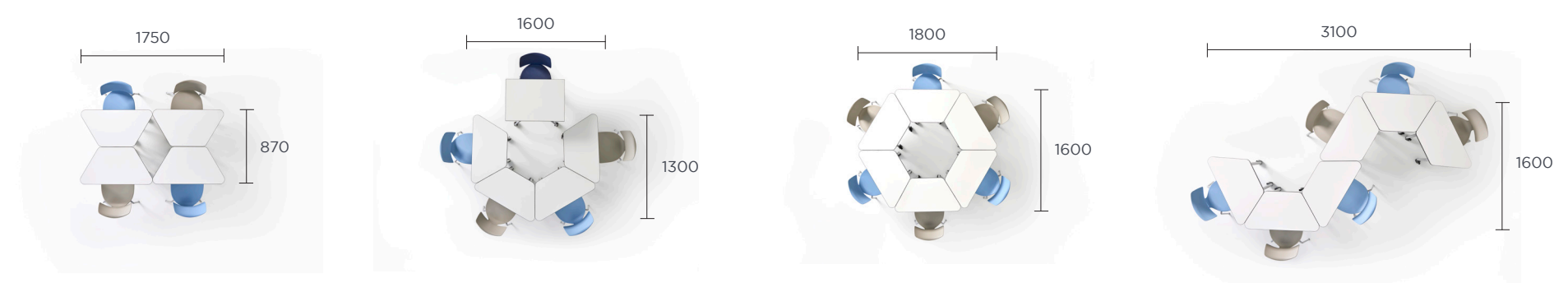



**Pupitre FG**  
Ref. MFG60X



112

**Pupitre FG estante de rejilla**  
Ref. MFG630X



**Pupitre FG estante de madera**  
Ref. MFG61X



**Pupitre bipersonal Modular**  
Ref. MM0664



**Pupitre bipersonal Ágil**  
Ref. MPM854



113

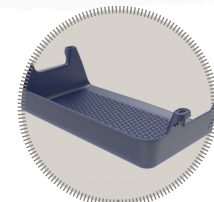

Opción gaveta

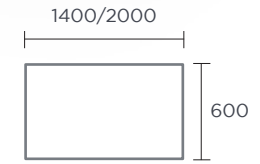
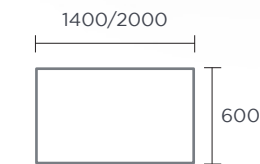
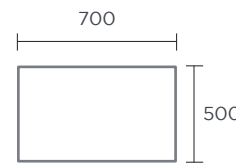

Tablero



Basic

Premium

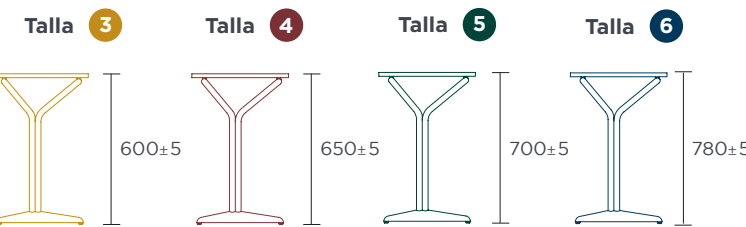

Superficie



Roble

Blanco

Patas



Aluminio

Blanco

Superficie



Roble

Blanco

Patas



Aluminio

Blanco

Tablero

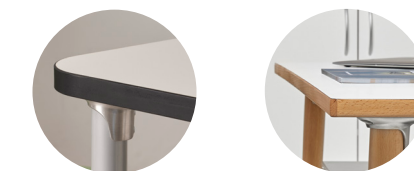

Basic

Premium



## ACTIFLEX® Wave

La colección Actiflex Wave es una apuesta por el diseño y la innovación. Compuesta de gradas, softseatings de tapizados variados y armarios móviles de diferentes alturas. Esta colección se ha concebido para crear espacios únicos y especiales donde disfrutar, a partes iguales, del trabajo y del descanso.

Actiflex Wave collection is a commitment to design and innovation. It is composed of bleachers, softseatings with varied upholstery and mobile cabinets of different heights. This collection has been conceived to create unique and special spaces where to enjoy, in equal parts, work and rest.



Ver colección



## Modelos



Armario recto



Armario curvo



Armario recto bajo



Armario curvo bajo



Softseating recto



Softseating curvo



Softseating recto bajo



Softseating curvo bajo



Softseating circular



Grada

**Armario recto bajo**  
Ref. AAC105

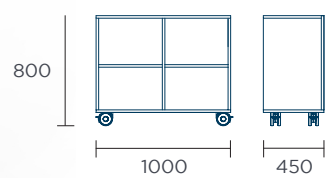
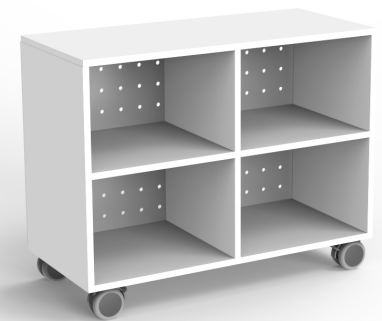

**Cuerpo**



Blanco

**Trasera**



Aluminio

**Armario recto alto**  
Ref. AAC100

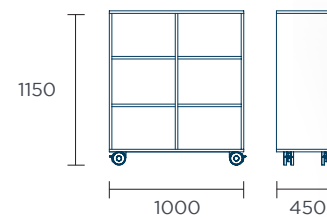

**Armario curvo bajo**  
Ref. AAC115

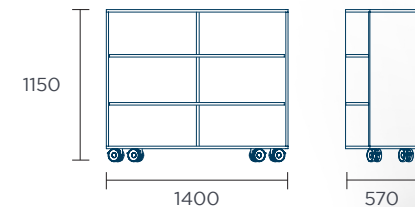
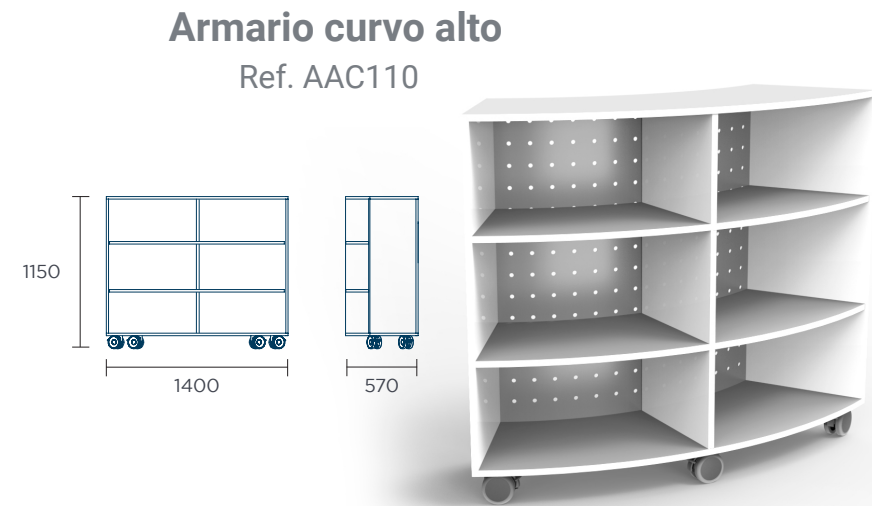
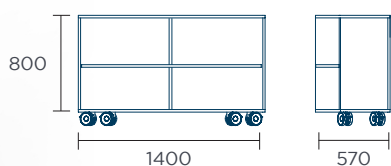
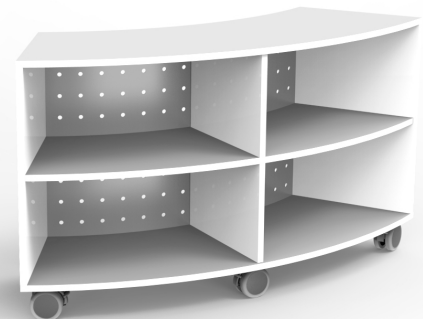

**Soft seating recto bajo**  
Ref. BAC105

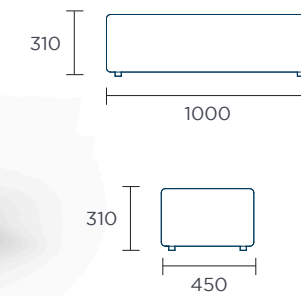

**Tela**



Delf

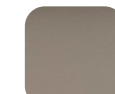

Macadamia



Forest

**Soft seating recto**  
Ref. BAC100

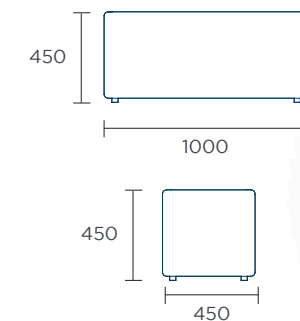

**Soft seating circular**  
Ref. BAC040

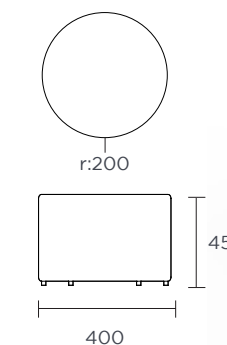

116

117



**Grada**  
Ref. GAC100



**Cuerpo**



Blanco

**Asiento**



Roble

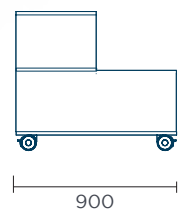
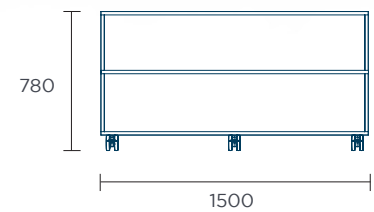

**Softseating curvo alto**  
Ref. BAC110

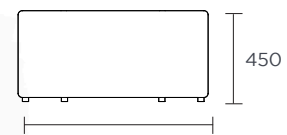
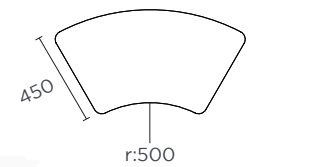

**Softseating curvo bajo**  
Ref. BAC115

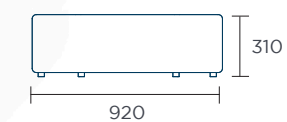
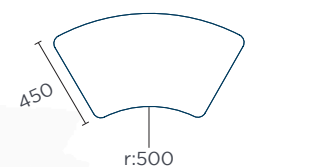

**Tela**



Delf

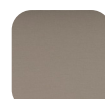

Macadamia



Forest

118

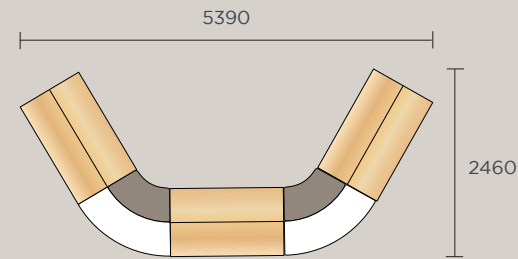
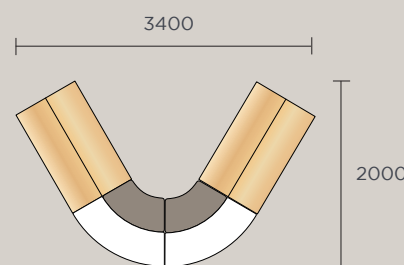
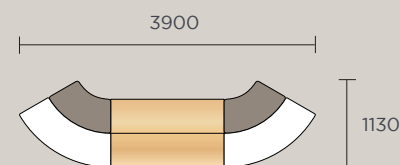
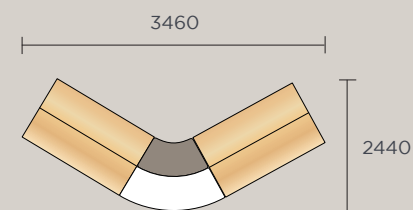



## SERP collection

La colección SERP se compone de cinco módulos de softseating cuidadosamente diseñados, la colección ofrece una experiencia cálida y cómoda en la creación de composiciones orgánicas adaptables a las diversas necesidades de tu espacio.

The SERP collection is composed of five carefully designed softseating modules, the collection offers a warm and comfortable experience in creating organic compositions adaptable to the diverse needs of your space.



## Modelos



SERP recto



SERP abierto



SERP cerrado



Mesa SERP



Mesa circular

**SERP Recto**  
Ref. SRE200

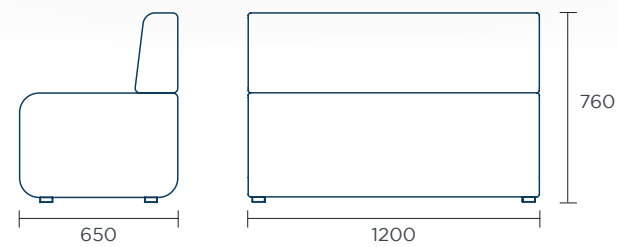

**SERP Curvo Abierto**  
Ref. SCA200

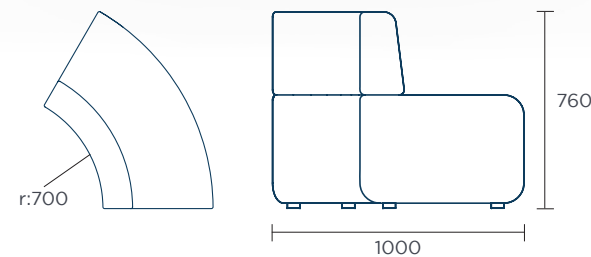

**Tela**



**SERP Curvo Cerrado**  
Ref. SCC200

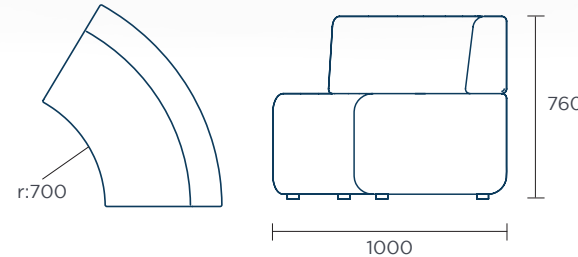

**Mesa SERP**  
Ref. MAC159

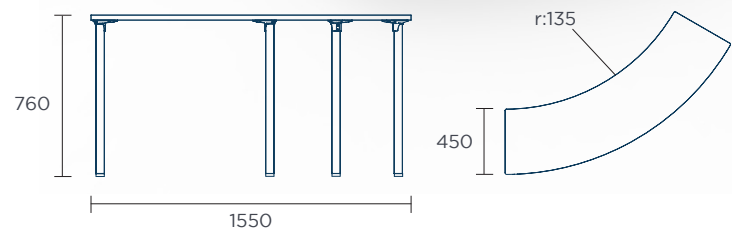

**Tablero**

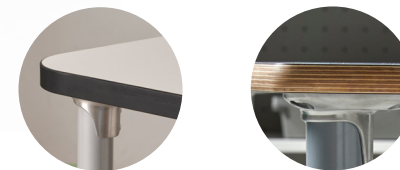

**Superficie**



**Patas**



**Mesa Circular SERP**  
Ref. MLO0006

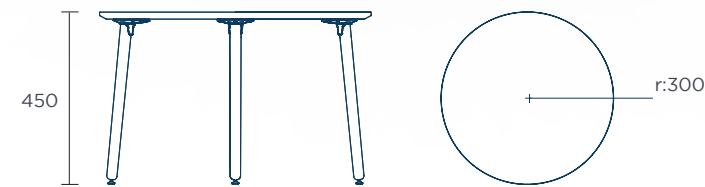

**Superficie**



**Patas**



# Armarios



## Estantería baja

Ref. ASB101

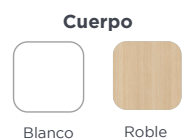

## Armario gavetero bajo

Ref. ASB104

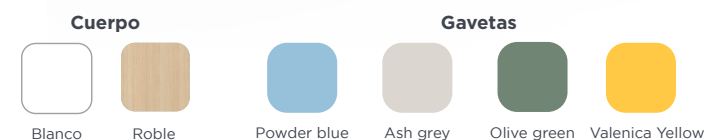

## Armario intermedio con puertas

Ref. ASM208

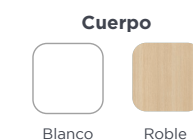
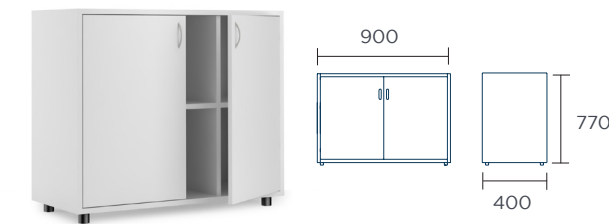

## Estantería intermedia

Ref. ASM201

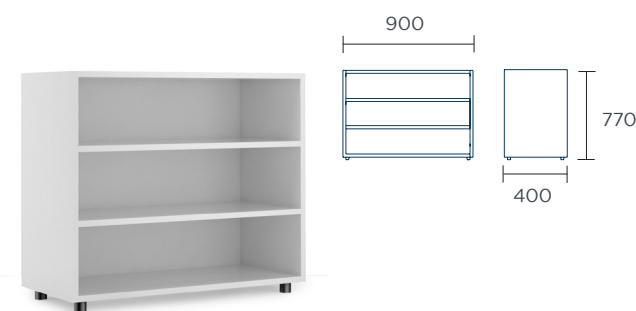

## Armario gavetero intermedio

Ref. ASM206

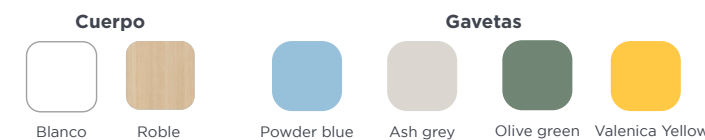
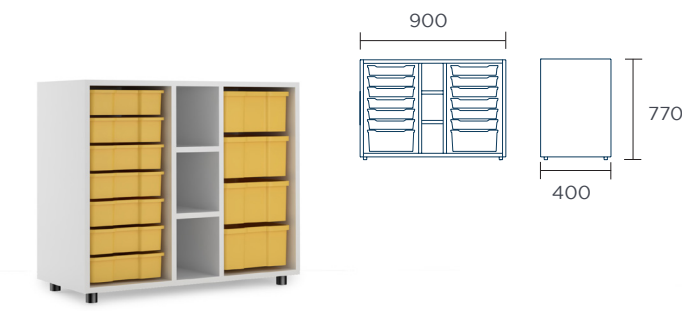

## Estantería Media

Ref. ASN301

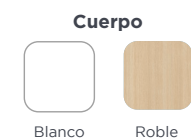
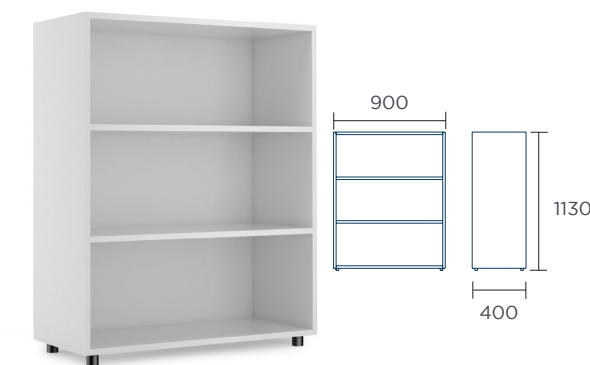

**Armario gavetero medio**  
Ref. ASN306

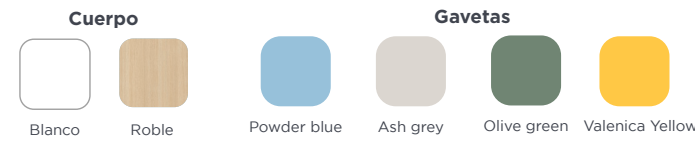

**Estantería media**  
Ref. ASA401

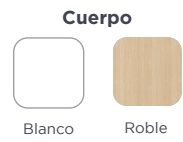

**Armario gavetero alto**  
Ref. ASA404

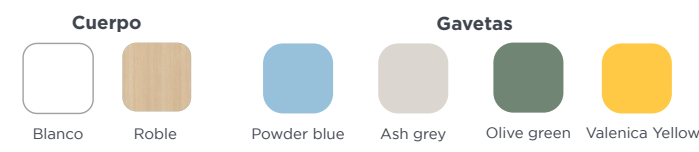
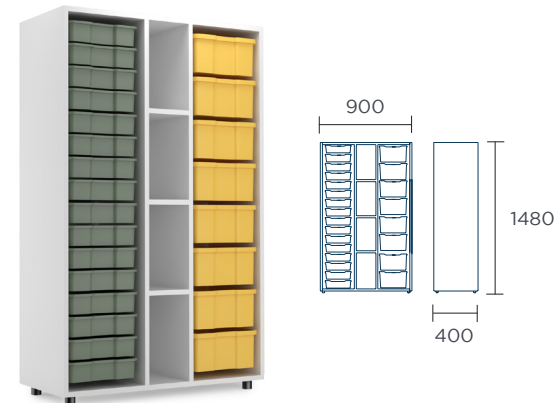

**Armario alto con puertas**  
Ref. ASA405

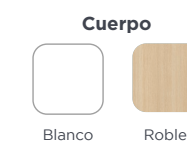

**Armario medio con puertas**  
Ref. ASN307



**Armario alto con puertas y estantes**  
Ref. ASA407

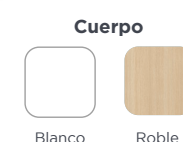

**Estantería super alta**  
Ref. ASA501

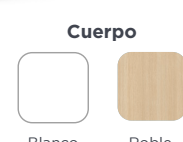
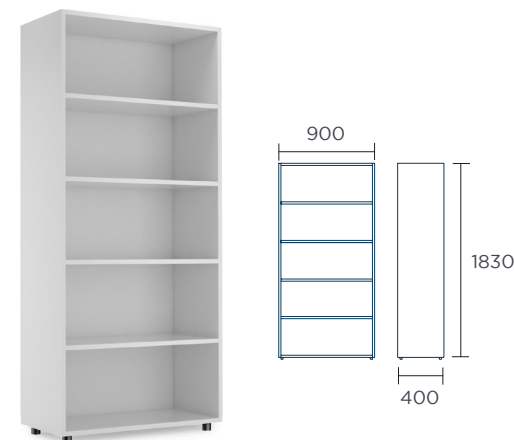

**Armario super alto con puertas**  
Ref. ASA502

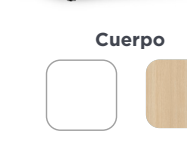



# FG Box

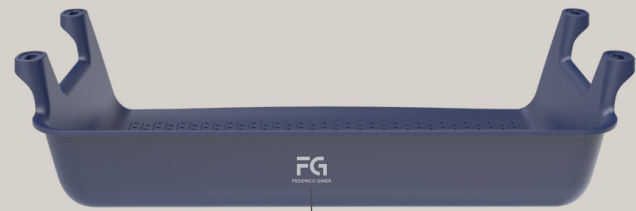
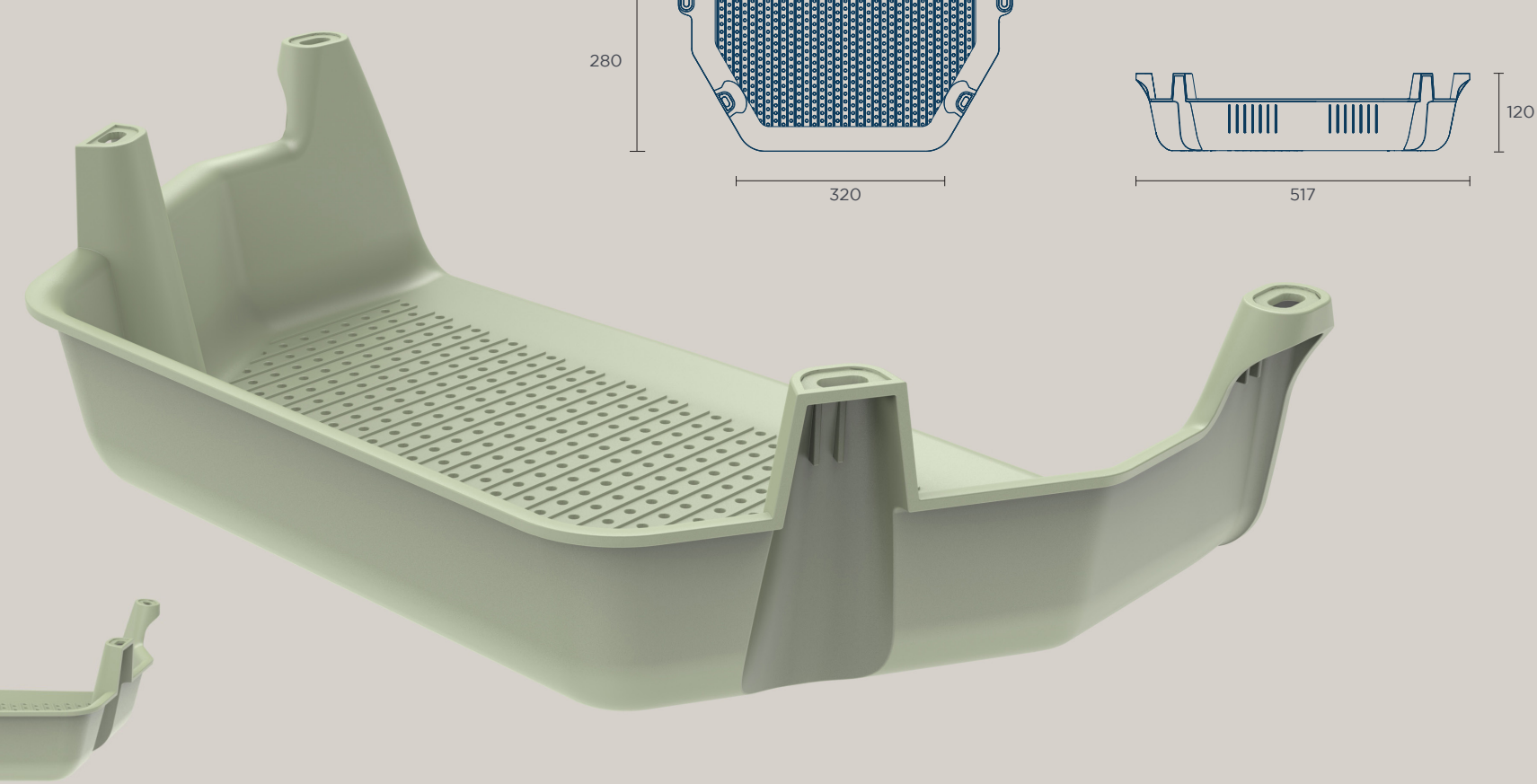
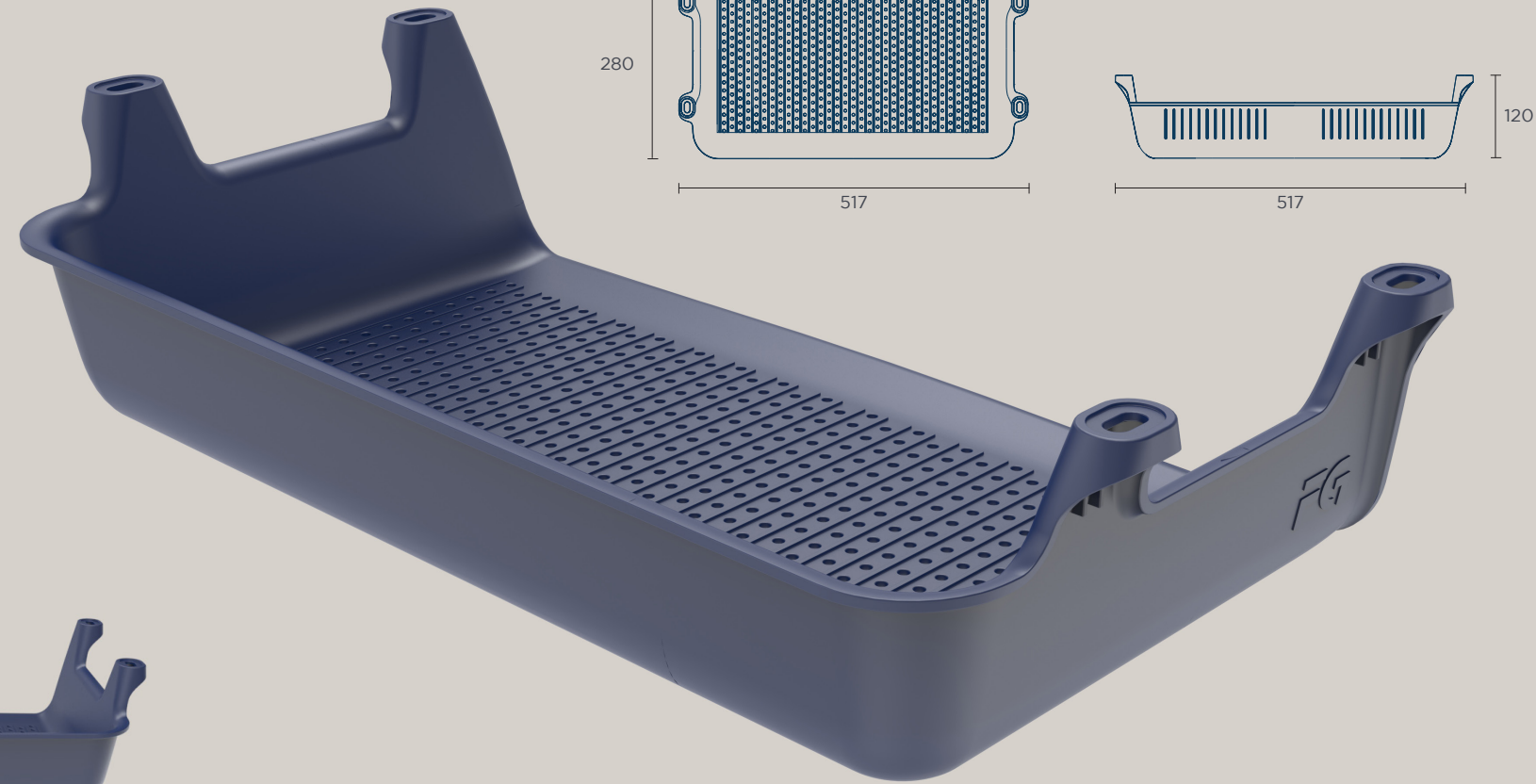

Opción:  
Logo personalizado

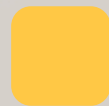

Valencia Yellow



Cayenne



Nordic

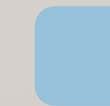

Powder Blue



Olive Green



Ash Grey

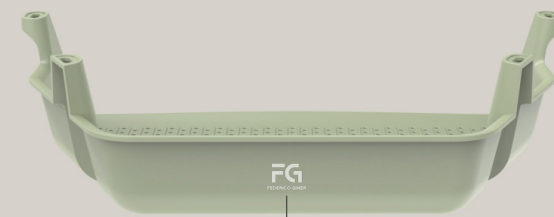

Opción:  
Logo personalizado

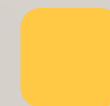

Valencia Yellow



Cayenne



Nordic



Powder Blue



Olive Green



Ash Grey

Mesa Mopac

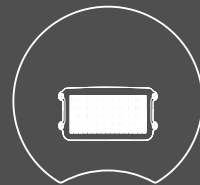

Mesa Link

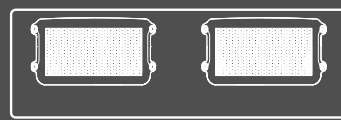

Mesa Loop

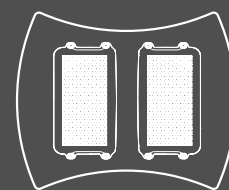

Mesa Half

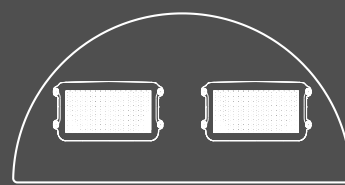

Pupitre DIDA Rectangular

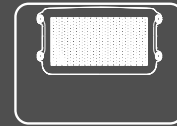

Pupitre DIDA Trapezoidal

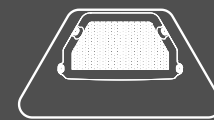

Mesa Half

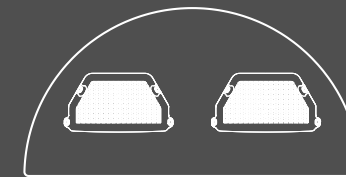

Mesa Loop

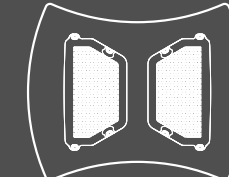

Mesa Link

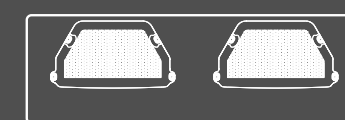

Mesa Mopac

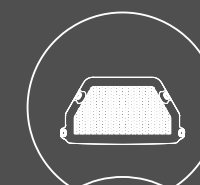

# Soluciones Acústicas



**Panel acústico cuadrado**  
Ref. PAC010

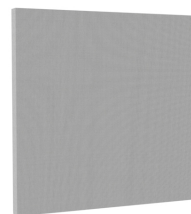

**Panel acústico circular**  
Ref. PAC030

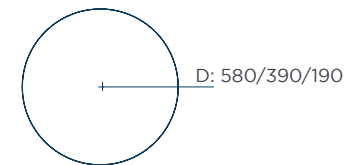
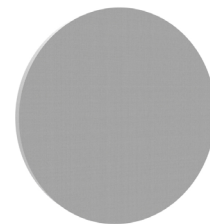

**Panel acústico onda**  
Ref. PAC040

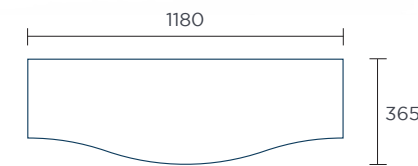

**Panel acústico rectangular**  
Ref. PAC020

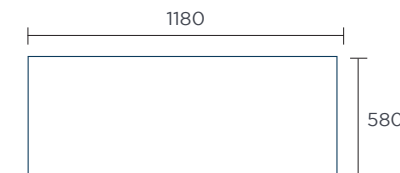
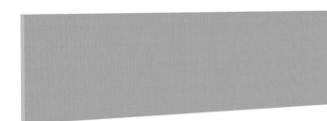

**Panel listones pared**  
Ref. PAL1206

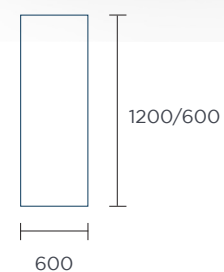

**Cabina acústica doble**  
Ref. CAD200

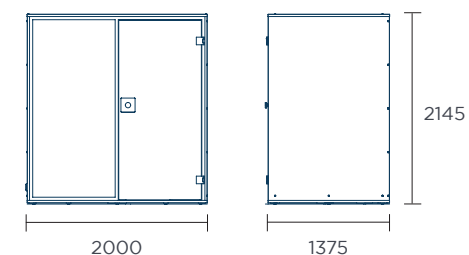

**Cabina acústica individual**  
Ref. CAS100

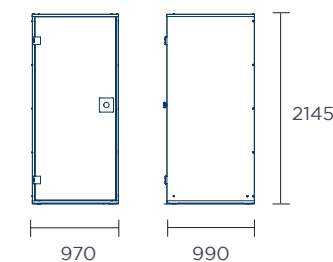



# 04

P T B A B O P V L C O E L O  
 C Y O B A Ñ C K W B A Q E A  
 Q C Ñ A Ñ W Q C D R K P Z K  
 R N G S B P K C I R S R K Y  
 Y X W S A B Y M O P R O O R  
 C U P P X W C T P Y A D E A  
 L Ñ L A Z B L Ñ V U I U M I  
 C P R C T L C L N Z Ñ C P Ñ  
 C Q H I A B C A G X J T T J  
**G U I A D E T A L L A S** L K  
 C L I S R Q C O K R L S S L  
 M Y K R E Z M P B W M V P M

04 Size Guide

## GUÍA DE TALLAS

\*Independientemente de las medidas de esta guía, cada producto tiene sus medidas específicas en su ficha comercial informativa. \*Todas las medidas se consideran en mm.











SEGÚN LA NORMATIVA UNE-EN 1729 SILLAS Y MESAS PARA CENTROS DE ENSEÑANZA.

### Normativa.

En **FEDERICO GINER** nos tomamos muy en serio la seguridad de nuestros diseños. Por eso, seguimos la norma **española y europea UNE-EN 1729** para centros de enseñanza, donde se regulan las dimensiones funcionales y los requisitos de seguridad del mobiliario escolar, en su primera y segunda parte.

Esta normativa codifica cada talla con un color y un número. Las tallas 0 y 1 son claramente tallas para centros infantiles de primera etapa (*escuelas infantiles*). El resto de tallas son las que se usan para el resto de etapas educativas.

Las medidas más importantes para determinar las tallas, son la altura total de los alumnos y el rango poplíteo. Estos se han determinado en base a estudios antropométricos y ergonómicos, siendo las medidas marcadas en la norma las más adecuadas para la adopción de una buena postura del alumno, y su menor fatiga durante el uso.

						
	<b>TALLA 1</b>	<b>TALLA 2</b>	<b>TALLA 3</b>	<b>TALLA 4</b>	<b>TALLA 5</b>	<b>TALLA 6</b>
Orientativo	INFANTIL	INFANTIL	PRIMARIA 1º-2º	PRIMARIA 3º-4º	PRIMARIA 5º-6º	SECUNDARIA
	0 - 3 años	3 - 5 años	5 - 6 años	6 - 9 años	9 - 11 años	+ de 11 años
	930 - 1160	1080 - 1210	1190 - 1420	1330 - 1590	1460 - 1765	1590 - 1880
	250 - 280	280 - 315	315 - 355	355 - 405	405 - 435	435 - 485
 ± 10	260	310	350	380	430	460
 ± 20	460	530	590	640	710	760



# 05

P T B A B O P V L C O E L O  
 C Y O B A Ñ C K W B A Q E A  
 Q C Ñ A Ñ W Q C D R K P Z K  
 R N **A** S B P K C I R S R K Y  
 Y X O **C** A B Y M O P R O O R  
 C U M P **A** W C T P Y A D E A  
 L Ñ B A Z **B** L Ñ V U I U M I  
 C P I C T L **A** L N Z Ñ C P Ñ  
 C Q H I A B C **D** G X J T T J  
 G U I A D E T A **O** L A S L K  
 C L I S R Q C O K **S** L S S L  
 M Y K R E Z M P B W M V P M

## ACABADOS

### Estructura metálica



Aluminio

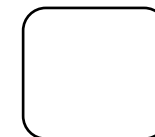

Blanco

### Tapas tableros

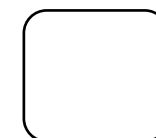

Blanco



Roble

### Tapas de mesas y pupitres / Tables and desks tops

#### Basic



Melamina

Tablero de partículas bilaminado con papel decorativo melamínico y resinas melamínicas resistentes de 25mm de espesor. Canteado en todo su perímetro con canto PVC encolado industrialmente.

Bi-laminated particle board with melamine decorative paper and resistant melamine resins, 25 mm thick. Edged all around with industrially glued PVC edging.

#### Premium



Contrachapado

Tablero con superficie HPL, laminado de alta presión, en ambas caras, con núcleo en contrachapado de madera de abedul, en espesores de 20/25mm y 30mm (biselado). Tablero para uso intensivo en espacios públicos.

Board with HPL surface, high pressure laminated on both sides, with birch plywood core, in thicknesses of 20/25mm and 30mm (bevelled). Board for intensive use in public spaces.



Macizado

Tablero con superficie HPL, laminado de alta presión, en ambas caras, con núcleo en tablero laminado de partículas y recubierto en todo su perímetro por madera maciza de haya de 10mm de espesor. En espesores de tablero de 21 y 27mm. Tablero para uso intensivo en espacios públicos.

Board with HPL surface, high pressure laminated on both sides, with core in laminated particle board and covered all around with 10mm thick solid beech wood. In board thicknesses of 21 and 27mm. Board for intensive use in public spaces.

### Postura +



### Dida

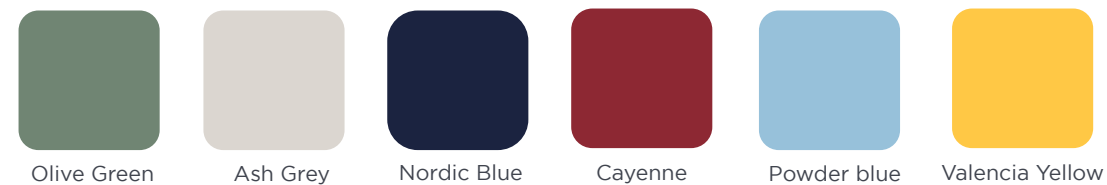

### Hatton



### Meet



### Telas Master Pro



### Telas Soft seating / SERP

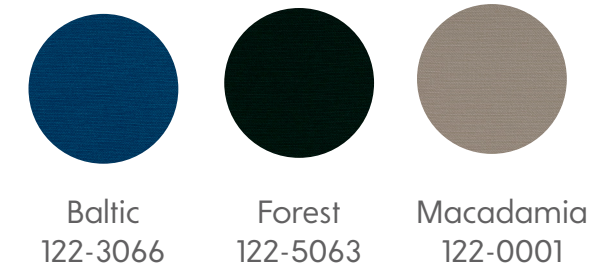

Más acabados



Más acabados



CATÁLOGO 2024  
RV.04/24

C/ Portalet esquina Ctra. Liria-Tavernes  
46760. Tavernes de la Valldigna. Valencia  
T. 96 282 40 50  
M. 608 218 939  
[info@federicoginer.com](mailto:info@federicoginer.com)  
[www.federicoginer.com](http://www.federicoginer.com)